



## Разъемы серии FPD-101

### Технические характеристики

<b>Архангельск</b> (8182)63-90-72	<b>Ижевск</b> (3412)26-03-58	<b>Магнитогорск</b> (3519)55-03-13	<b>Пермь</b> (342)205-81-47	<b>Сургут</b> (3462)77-98-35
<b>Астана</b> (7172)727-132	<b>Иркутск</b> (395)279-98-46	<b>Москва</b> (495)268-04-70	<b>Ростов-на-Дону</b> (863)308-18-15	<b>Тверь</b> (4822)63-31-35
<b>Астрахань</b> (8512)99-46-04	<b>Казань</b> (843)206-01-48	<b>Мурманск</b> (8152)59-64-93	<b>Рязань</b> (4912)46-61-64	<b>Томск</b> (3822)98-41-53
<b>Барнаул</b> (3852)73-04-60	<b>Калининград</b> (4012)72-03-81	<b>Набережные Челны</b> (8552)20-53-41	<b>Самара</b> (846)206-03-16	<b>Тула</b> (4872)74-02-29
<b>Белгород</b> (4722)40-23-64	<b>Калуга</b> (4842)92-23-67	<b>Нижний Новгород</b> (831)429-08-12	<b>Санкт-Петербург</b> (812)309-46-40	<b>Тюмень</b> (3452)66-21-18
<b>Брянск</b> (4832)59-03-52	<b>Кемерово</b> (3842)65-04-62	<b>Новокузнецк</b> (3843)20-46-81	<b>Саратов</b> (845)249-38-78	<b>Ульяновск</b> (8422)24-23-59
<b>Владивосток</b> (423)249-28-31	<b>Киров</b> (8332)68-02-04	<b>Новосибирск</b> (383)227-86-73	<b>Севастополь</b> (8692)22-31-93	<b>Уфа</b> (347)229-48-12
<b>Волгоград</b> (844)278-03-48	<b>Краснодар</b> (861)203-40-90	<b>Омск</b> (3812)21-46-40	<b>Симферополь</b> (3652)67-13-56	<b>Хабаровск</b> (4212)92-98-04
<b>Вологда</b> (8172)26-41-59	<b>Красноярск</b> (391)204-63-61	<b>Орел</b> (4862)44-53-42	<b>Смоленск</b> (4812)29-41-54	<b>Челябинск</b> (351)202-03-61
<b>Воронеж</b> (473)204-51-73	<b>Курск</b> (4712)77-13-04	<b>Оренбург</b> (3532)37-68-04	<b>Сочи</b> (862)225-72-31	<b>Череповец</b> (8202)49-02-64
<b>Екатеринбург</b> (343)384-55-89	<b>Липецк</b> (4742)52-20-81	<b>Пенза</b> (8412)22-31-16	<b>Ставрополь</b> (8652)20-65-13	<b>Ярославль</b> (4852)69-52-93
<b>Иваново</b> (4932)77-34-06	<b>Киргизия</b> (996)312-96-26-47	<b>Казахстан</b> (772)734-952-31	<b>Таджикистан</b> (992)427-82-92-69	

Единый адрес для всех регионов: [fst@nt-rt.ru](mailto:fst@nt-rt.ru) || [www.fujitsu.nt-rt.ru](http://www.fujitsu.nt-rt.ru)

# FUJITSU Component Connector o-microGiGaCN™ 4-Channel Optical Transceiver

RoHS compliant

## Overview

Newly developed optical transceiver, FUJITSU COMPONENT's o-microGiGaCN series supports electric to optical interface conversion and provides 2.5 Gbps x 4 channel, bidirectional data transfer. The electrical interface is FUJITSU COMPONENT's industry standard high-speed differential copper connector, microGiGaCN™ that has been selected by InfiniBand™, 10G Ethernet, and 10G FibreChannel.

The o-microGiGaCN makes it possible to extend transmission length up to 300m (2.5Gbps) over fiber optic cable from Industry Standard 4 lane copper cable with Media Detection Circuit (connector detect and power supply circuit) on the customer's board/host side.

The module provides flexibility, allowing the user to select interface options with the one low cost copper I/O connector on the board. The module provides a low cost solution for data center requirements.



o-microGiGaCN

## Features

- Converts 4x microGiGaCN to 4x optical interface
- Optical interface 12-channel MPO connector
- Up to 100m links with standard 50/125µm MMF ribbon cable at 3.125Gbps and up to 300m at 2.5Gbps
- Reliable, low cost 850nm VCSEL technology
- 0 to +50°C operating temperature range
- Low power: 0.9 watts typical with 3.3V power supply through connector
- Hot pluggable electrical interface
- IEC Class 1M laser eye safety compliant

### ■ Absolute maximum rating

Item	Minimum	Typical	Maximum
Storage temperature	-20°C	-	+85°C
Relative humidity (no frost)	5% RH	-	95% RH
Supply voltage	3.14V	3.3V	3.47V

Stress beyond the values stated above may cause permanent damage to the device. Exposure to absolute maximum rating conditions for extended periods of time may affect device's reliability.

### ■ Recommended operating conditions

Item	Minimum	Typical	Maximum
Operating temperature	0°C	-	+50°C
Operating humidity (no frost)	-	-	85% RH
Operating case temperature	0°C	-	+70°C
Differential peak-to-peak input voltage	100mV <sub>p,p</sub>	-	1,600mV <sub>p,p</sub>

Notes: 1. Transmitter Differential Input Voltage = (Vin+p-p) – (Vin-p-p)  
2. Limits assume PRBS2<sup>23</sup>-1. Signaling rates lower than indicated may be used with encoding schemes such as 8B/10B coding.

### ■ Receiver electrical characteristics

Item	Minimum	Typical	Maximum
Differential peak-to-peak output voltage	400mV	-	800mV
Contributed deterministic jitter	-	-	54ps
Contributed total jitter	-	-	112ps*

Notes: Operating temperature: +20°C to +50°C, power supply 3.14V to 3.47V.  
\*: Outputs are compatible with 10K, 10KH, 100K ECL and PECL inputs.

### ■ Optical transmitter characteristics (reference)

Item	Minimum	Typical	Maximum
Optical power output	-4.0 dBm	-	-2.0 dBm average
Optical power input	-	-	BER <10 <sup>-12</sup>
Wavelength	830nm	850nm	860nm

Note: Operating temperature +20°C to +50°C, power supply 3.14V to 3.47V.

### ■ Laser Eye Safety

The transceiver comply with Laser Product Class 1M laser eye safety requirements per IEC/EN 60825-1 Amendment 2: 2001.

### ■ LED indicator

LED light	Status
No light	The power is not supplied
Green light	Power on, optical power input >-17dBm
Green and red light	Power on, optical power input <-30dBm

■ Link overview

- Optical link carries a double 4x link as shown in Figure 1

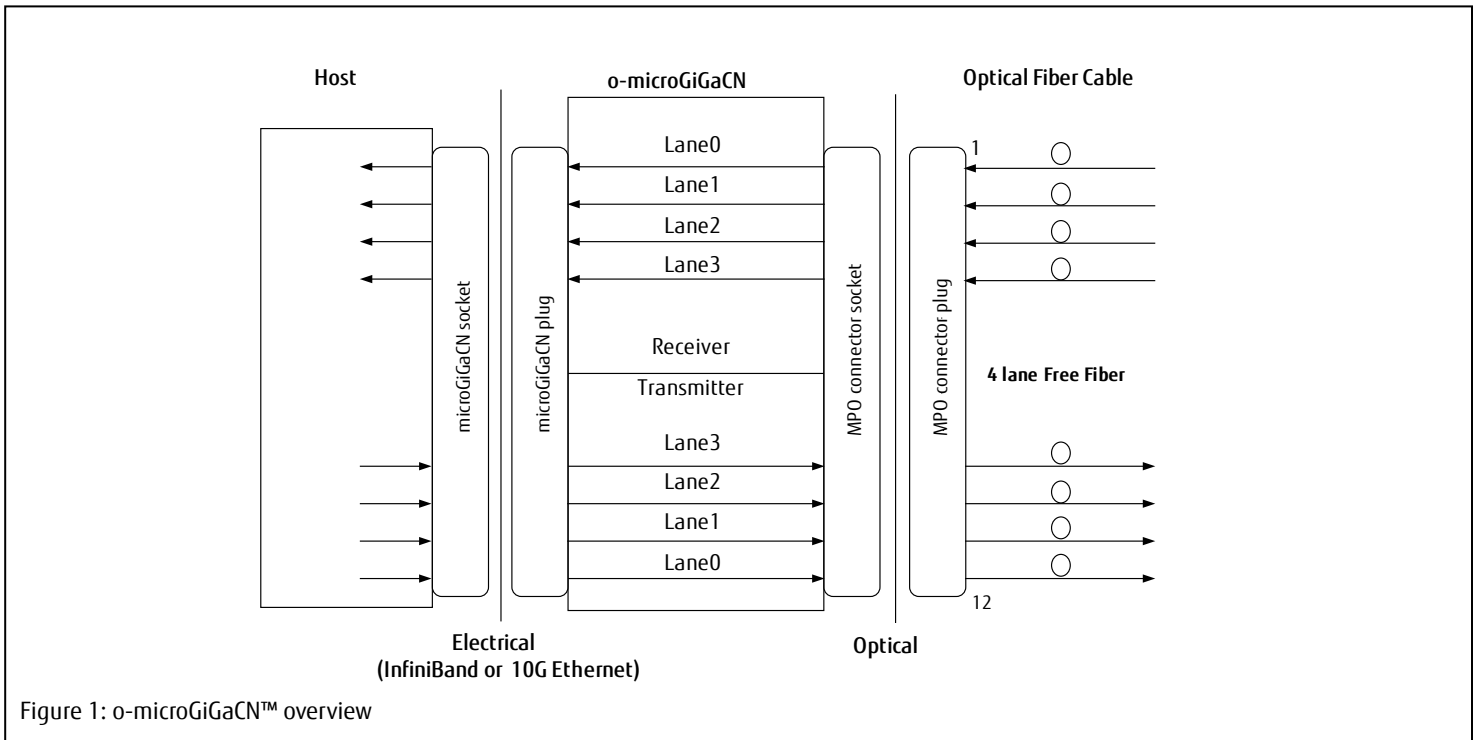

Figure 1: o-microGiGaCN™ overview

■ Link distance

The table below lists the reach distance of the o-microGiGaCN™ for different multi-mode (MMF) types and bandwidths. Each case includes a maximum of 2 dB per channel connection loss for path cables.

Data rate \ MMF type	GI 50/125um 500MHz.km	GI 50/125um 2,000MHz.km
2.5 Gbps / channel	300m	500m
3.125 Gbps / channel	100m	300m

■ Optical fiber cable specification

Item	Value
Connector type	MPO/MTP
Polishing	Flat polishing
Polarity	Without pin
Channel	12 channels
Fiber type	Multi-mode, 50/125um, GI, ribbon type
Insertion loss	1.0dB max.
Transmission band	500MHz*km or 2,000MHz*km

## ■ Power supply to the o-microGiGaCN™

- Pin assignment if FC-PI-2

The microGiGaCN™ usually does not provide power for the module. The draft proposal of FC-PI-2 allows the re-assignment of some ground pins as power pins, as shown in the following table.

This re-assignment does not affect the function or performance of standard cable connection for InfiniBand™ and 10G Ethernet applications, as the power is added only when the system is sure the attached module is “active”. The re-assigned pins are all AC ground to minimize the effect on high-speed signal integrity.

Connector pin number	Alternate signal definition
G1	Signal ground
G2	ODIS
G3	Signal ground
G4	Signal ground
G5	Signal ground
G6	Fault-
G7	Type_Sense
G8	Vcc
G9	Signal ground
S1	RX0+
S2	RX0-
S3	RX1+
S4	RX1-
S5	RX2+
S6	RX2-
S7	RX3+
S8	RX3-
S9	TX3-
S10	TX3+
S11	TX2-
S12	TX2+
S13	TX1-
S14	TX1+
S15	TX0-
S16	TX0+
Housing	Chassis ground

FUJITSU COMPONENT recommends the following figure 2 on customer's board to perform the media detect function. The circuitry uses less than 1/4 square inch of board space on a single layer, and uses less than 1mA of current.

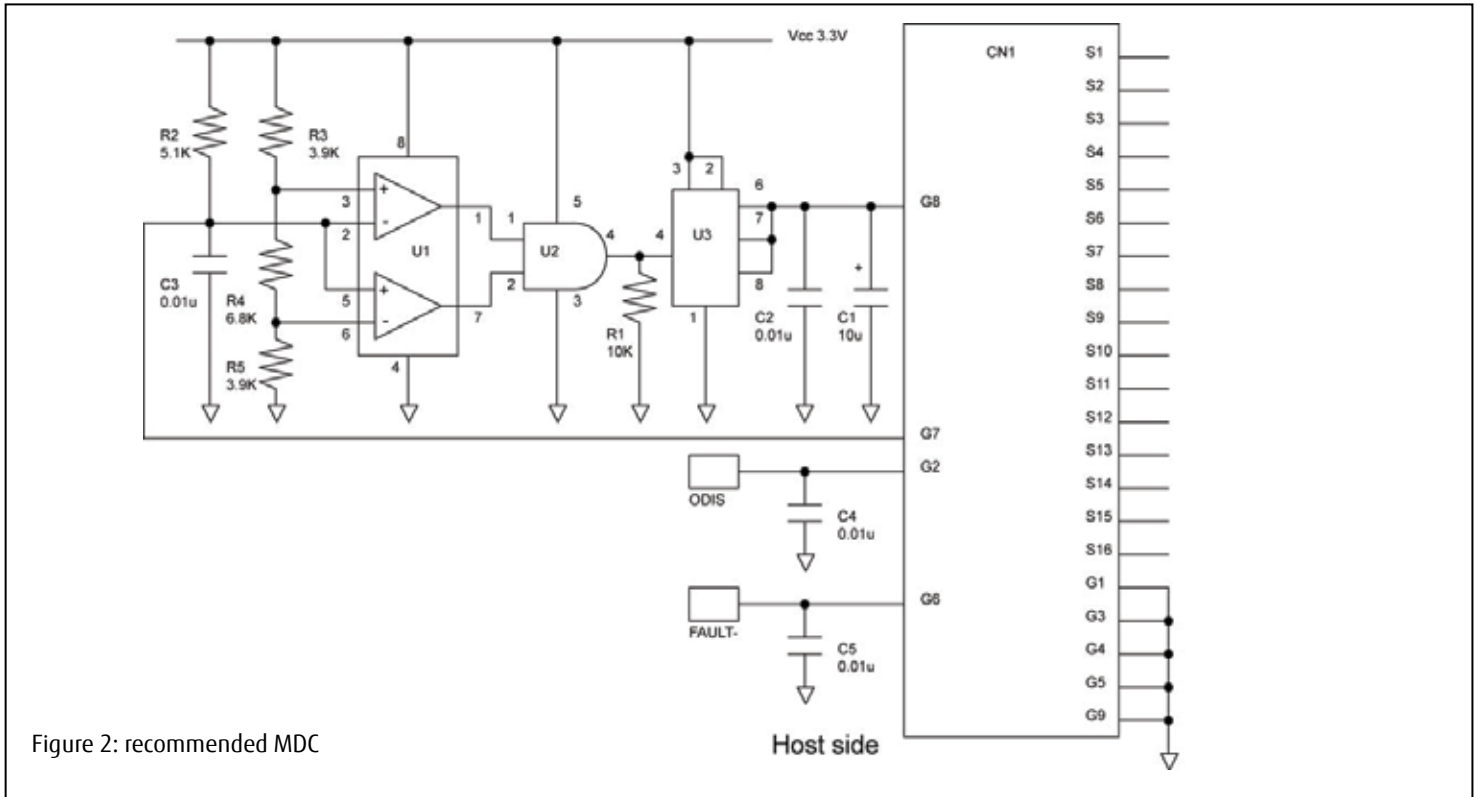

Figure 2: recommended MDC

■ Recommended MDC parts

ODIS (Optics Disable) -Input-: Disable the optics when this signal is pull HIGH. Enables the optics when this signal is pull LOW. If it is tied to GND then the optical transmitter is default on when power is applied.

FAULT- (TX\_Fault Indicator) -Open Drain Output-: It is default high, and will turn low when there is a fault. Shorting this pin to ground will not affect the performance of the module.

Item	Designation	Description	Quantity	Manufacturer	Part Number
1	U1	Dual push-pull output comparator	1	Maxim	MAX9032AKA
2	R2	5.1K 0402 resistor	1		
3	R1	10K 0402 resistor	1		
4	R3, R5	3.9K 0402 resistor	2		
5	R4	6.8K resistor 0402 resistor	1		
6	C3, C4, C5	0.01 uF ceramic 0402 capacitor	3		
7	U2	Single 2-input positive AND gate	1	TI	SN74AHC1G08DCKR
8	U3	Power distribution switch	1	TI	TPS2031D
9	C2	0.1 uF ceramic 0402 capacitor	1		
10	C1	10 uF Tantalum case B capacitor	1		
11	CN1	microGiGaCN™	1	Fujitsu Component	

■ Part Numbers

Part Number	Data rate
FPD-101R008-2E	3.125 Gbps / channel

■ Dimensions

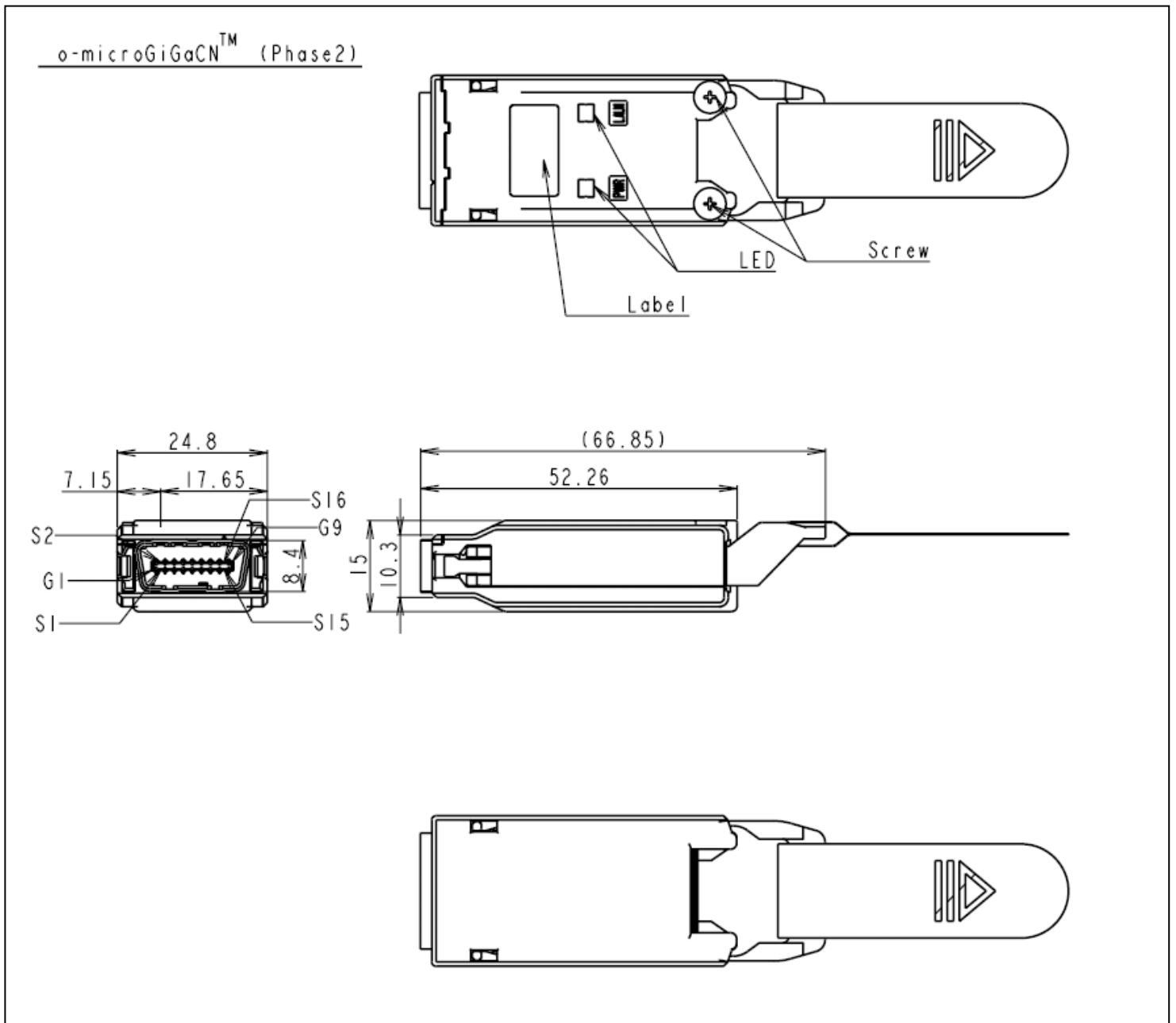

<b>Архангельск (8182)63-90-72</b>	<b>Ижевск (3412)26-03-58</b>	<b>Магнитогорск (3519)55-03-13</b>	<b>Пермь (342)205-81-47</b>	<b>Сургут (3462)77-98-35</b>
<b>Астана (7172)727-132</b>	<b>Иркутск (395)279-98-46</b>	<b>Москва (495)268-04-70</b>	<b>Ростов-на-Дону (863)308-18-15</b>	<b>Тверь (4822)63-31-35</b>
<b>Астрахань (8512)99-46-04</b>	<b>Казань (843)206-01-48</b>	<b>Мурманск (8152)59-64-93</b>	<b>Рязань (4912)46-61-64</b>	<b>Томск (3822)98-41-53</b>
<b>Барнаул (3852)73-04-60</b>	<b>Калининград (4012)72-03-81</b>	<b>Набережные Челны (8552)20-53-41</b>	<b>Самара (846)206-03-16</b>	<b>Тула (4872)74-02-29</b>
<b>Белгород (4722)40-23-64</b>	<b>Калуга (4842)92-23-67</b>	<b>Нижний Новгород (831)429-08-12</b>	<b>Санкт-Петербург (812)309-46-40</b>	<b>Тюмень (3452)66-21-18</b>
<b>Брянск (4832)59-03-52</b>	<b>Кемерово (3842)65-04-62</b>	<b>Новокузнецк (3843)20-46-81</b>	<b>Саратов (845)249-38-78</b>	<b>Ульяновск (8422)24-23-59</b>
<b>Владивосток (423)249-28-31</b>	<b>Киров (8332)68-02-04</b>	<b>Новосибирск (383)227-86-73</b>	<b>Севастополь (8692)22-31-93</b>	<b>Уфа (347)229-48-12</b>
<b>Волгоград (844)278-03-48</b>	<b>Краснодар (861)203-40-90</b>	<b>Омск (3812)21-46-40</b>	<b>Симферополь (3652)67-13-56</b>	<b>Хабаровск (4212)92-98-04</b>
<b>Вологда (8172)26-41-59</b>	<b>Красноярск (391)204-63-61</b>	<b>Орел (4862)44-53-42</b>	<b>Смоленск (4812)29-41-54</b>	<b>Челябинск (351)202-03-61</b>
<b>Воронеж (473)204-51-73</b>	<b>Курск (4712)77-13-04</b>	<b>Оренбург (3532)37-68-04</b>	<b>Сочи (862)225-72-31</b>	<b>Череповец (8202)49-02-64</b>
<b>Екатеринбург (343)384-55-89</b>	<b>Липецк (4742)52-20-81</b>	<b>Пенза (8412)22-31-16</b>	<b>Ставрополь (8652)20-65-13</b>	<b>Ярославль (4852)69-52-93</b>
<b>Иваново (4932)77-34-06</b>	<b>Киргизия (996)312-96-26-47</b>	<b>Казахстан (772)734-952-31</b>	<b>Таджикистан (992)427-82-92-69</b>	

Единый адрес для всех регионов: [fst@nt-rt.ru](mailto:fst@nt-rt.ru) || [www.fujitsu.nt-rt.ru](http://www.fujitsu.nt-rt.ru)