



Низковольтные термопечатающие механизмы FTP-628 MCL053/054 Технические характеристики

Архангельск (8182)63-90-72	Ижевск (3412)26-03-58	Магнитогорск (3519)55-03-13	Пермь (342)205-81-47	Сургут (3462)77-98-35
Астана (7172)727-132	Иркутск (395)279-98-46	Москва (495)268-04-70	Ростов-на-Дону (863)308-18-15	Тверь (4822)63-31-35
Астрахань (8512)99-46-04	Казань (843)206-01-48	Мурманск (8152)59-64-93	Рязань (4912)46-61-64	Томск (3822)98-41-53
Барнаул (3852)73-04-60	Калининград (4012)72-03-81	Набережные Челны (8552)20-53-41	Самара (846)206-03-16	Тула (4872)74-02-29
Белгород (4722)40-23-64	Калуга (4842)92-23-67	Нижний Новгород (831)429-08-12	Санкт-Петербург (812)309-46-40	Тюмень (3452)66-21-18
Брянск (4832)59-03-52	Кемерово (3842)65-04-62	Новокузнецк (3843)20-46-81	Саратов (845)249-38-78	Ульяновск (8422)24-23-59
Владивосток (423)249-28-31	Киров (8332)68-02-04	Новосибирск (383)227-86-73	Севастополь (8692)22-31-93	Уфа (347)229-48-12
Волгоград (844)278-03-48	Краснодар (861)203-40-90	Омск (3812)21-46-40	Симферополь (3652)67-13-56	Хабаровск (4212)92-98-04
Вологда (8172)26-41-59	Красноярск (391)204-63-61	Орел (4862)44-53-42	Смоленск (4812)29-41-54	Челябинск (351)202-03-61
Воронеж (473)204-51-73	Курск (4712)77-13-04	Оренбург (3532)37-68-04	Сочи (862)225-72-31	Череповец (8202)49-02-64
Екатеринбург (343)384-55-89	Липецк (4742)52-20-81	Пенза (8412)22-31-16	Ставрополь (8652)20-65-13	Ярославль (4852)69-52-93
Иваново (4932)77-34-06	Киргизия (996)312-96-26-47	Казахстан (772)734-952-31	Таджикистан (992)427-82-92-69	

Единый адрес для всех регионов: fst@nt-rt.ru || www.fujitsu.nt-rt.ru

BATTERY DRIVEN, FTP-608 Series 2" HIGH SPEED THERMAL PRINTER

FTP-628MCL053/054

■ OVERVIEW

The FTP-628 MCL Series are battery driven high-speed ultracompact printers with a 2-inch paper width equivalent. Paper can be easily set using our unique platen release mechanism.

The FTP-628 MCL Series can be used for a variety of applications, such as portable terminals, POS, ticket issuing terminals, label printers, banking terminals, and measurement and medical equipment.



■ HIGHLIGHTS

- **Ultra compact**
Height 15.5 mm, width 69.6 mm, depth 34.3 mm
- **High speed printing**
It can print at 80 mm/s (640 dotlines/s) maximum by using Fujitsu's unique head drive control.
- **High resolution printing / Kanji supported**
8 dots/mm of resolution printing is possible.
- **Auto paper loading**
Our unique platen release mechanism allows a wide paper route even if the printer is ultra-compact, so paper can be easily inserted. Conventional auto loading is also available.
- **Two types of paper routes**
Front or bottom feed, depending on the paper route.
- **Easy mounting**
Wiring for the head, motor, sensor are housed within one flexible cable (053, 054) or in two cables (051, 052). The mechanism can be secured by one hook and two screws at two locations, making mounting easy.
- **RoHS compliant**

■ PART NUMBERS

		Part Number
Printer mechanism		FTP-628MCL053 (front paper insertion with head open detection switch and knob) FTP-628MCL054 (bottom paper feed insertion with head open detection switch)
LSI for driving		FTP-628CU301R (ANK only) FTP-628CU601R
Interface board	Parallel	FTP-628DCL300 (Centronics)
	Serial	FTP-628DSL305 (RS232C) FTP-628DSL603 (hi-speed RS232C)
	USB	FTP-628DSL602R (V2.0)
Interface cables	Parallel	FTP-628Y202
	Serial	FTP-628Y302
Power cable	Head, motor	FTP-628Y402

■ SPECIFICATIONS

Item	Specifications
Part number	FTP-628MCL053/054
Printing method	Thermal-line dot method
Dot structure	384 dots/line
Dot pitch (Horizontal)	0.125 mm (8 dots/mm)—Dot density
Dot pitch (Vertical)	0.125 mm (8 dots/mm)—Line feed pitch
Effective printing area	48 mm
Number of columns	ANK 32 columns/line (maximum 12 x 24 dot font)
Paper width	58 mm ⁺⁰ _{-0.1}
Paper thickness	60 to 100 μ m (some paper in this range may not be used because of paper characteristics)
Printing Speed	Maximum 80mm/sec. (640 dot line/sec.) at 8.5V
Character types	Alphanumeric, katakana: 159 types International and special characters: 195 types JIS Kanji level 1, level 2, non-Kanji (supported only by FTP-628DSL228, DCL208): about 6800 types
Character, dimensions (W×H), number of columns	12 × 24 dots, (1.54 × 3.0 mm), 32 columns: alphanumeric, katakana 24 × 24 dots, (3.0 × 3.0 mm), 16 columns: alphanumeric, katakana, Kanji 8 × 16 dots, (1.0 × 2.0 mm), 48 columns: alphanumeric, katakana 16 × 16 dots, (1.0 × 2.0 mm), 24 columns: alphanumeric, katakana, Kanji

■ SPECIFICATIONS

Item		Specifications	
Interface		Conforms to RS232C / centronics	
Power supply	For print head	4.2 to 8.5VDC average current, 0.87 (0.93) A peak value (print ratio: 12.5%, print speed: 50mm/sec. at 7.2V)	
	For motor	4.2 to 8.5VDC, 1A maximum Note: 5.8 to 8.5V is recommended for automatic paper loading	
	For logic	3.0 to 5.25VDC, 0.1A maximum	
Dimension W x D x H	Printer mechanism	MCL053 83.5 x 35.7 x 15.5mm	
		MCL054 72.3 x 34.3 x 15.5mm	
	Interface board	69.3 x 34.3 x 15.5mm	
Weight	Printer mechanism	MCL053 Approximately 49g (with knob)	
		MCL054 Approximately 47g	
	Interface board (std)	Approximately 20g	
Head Life		Pulse resistance: 100 million pulse/dot (using Fujitsu's standard driving method) Abrasion resistance: paper traveling distance 50km (at 12.5% print ratio or less)	
Environmental conditions	Operating temperature	-10°C to +50°C	
	Operating humidity	20 to 85% RH (no condensation)	
	Storage temperature	-20°C to +60°C	
	Storage humidity	5 to 90% RH (no condensation)	
Detection	Head temperature	Detected by thermistor	
	Paper out/mark detect	Detected by photointerruptor	
	Head up detection	Detected by micro-switch	
Recommended thermal sensitive paper	High sensitive paper	TF50KS-E4 (Nippon paper)	
	Standard paper	TF60KS-E2 (Nippon paper) FTP-020PU001 (58mm) PD150R (Oji paper) FTP-020P0701 (58mm)	
		Medium life paper	TF60KS-F1 (Nippon paper) FTP-020P0102 (58mm) PD170R (Oji paper) P220VBB-1 (Mitsubishi paper)
		Long life paper	PD160R-N (Oji paper)

*+5°C to +40°C printing density assurance range (-25 to 70°C capability)

■ DIMENSIONS

1. Printer mechanism

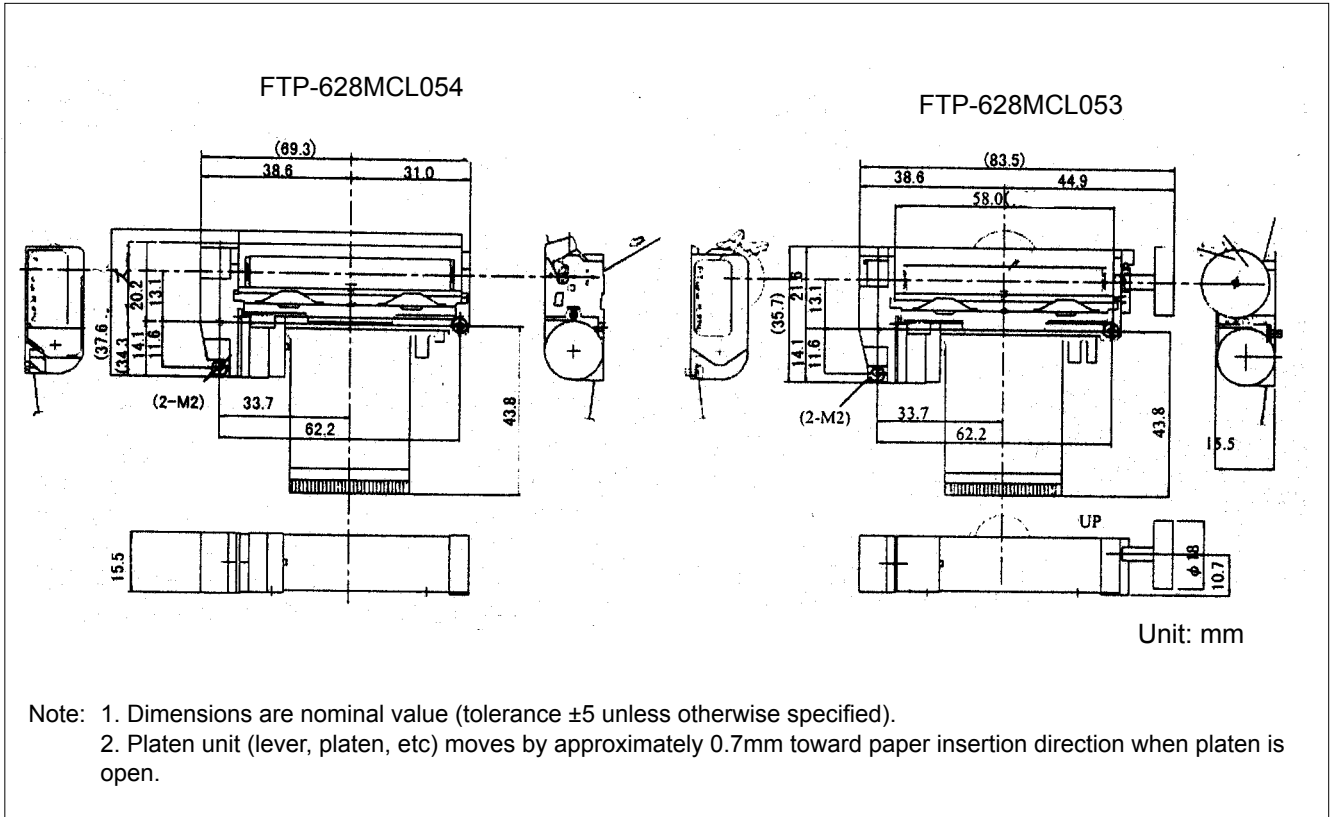

Connector (FPC) specification

(1) Connector

Mechanical unit side: FPC connector

Remote side (housing site): 52030-3071 (made by Molex)

(2) Pin assignment on the mechanical side

No	Signal	I/O	Contents
1	PHK	—	Cathode for photo interruptor
2	VSEN	I	paper sensor power
3	PHE	O	Emitter for photo interruptor
4	SW1	O	Platen release switch
5	SW2	I	Platen release switch
6	VH	I	Head drive power
7	VH	I	
8	DI	I	Data in
9	CLK	I	Synchronous clock for communication
10	GND	—	Ground power supply for thermal head
11	GND	—	
12	STB6	I	Thermal head energizing control signal
13	STB5	I	
14	STB4	I	
15	VDD	I	Logic power
16	TM	O	Thermally sensitive resistor input termnial 1
17	TM	O	Thermally sensitive resistor input termnial 2
18	STB3	I	Thermal head energizing control signal
19	STB2	I	
20	STB1	I	
21	GND	—	Ground power supply for thermal head
22	GND	—	
23	LAT	I	Data latch
24	DO	O	Data out
25	VH	I	Power supply for thermal head
26	VH	I	
27	MT A	I	Stepping motor excitation signal
28	MT A	I	
29	MT B	I	
30	MT B	I	

■ FUNCTION OF INTERFACE BOARD

Item	Item
1. Test print function	8. Motor power saving function
2. Paper out detection	9. Mark detection function
3. Paper near end detection	10. MCU operation abnormality detection
4. Platen open detection	11. Power ON/OFF sequence protection
5. Thermal head temperature abnormality detection	12. Motor over-current protection
6. Blow-out fuse detection	13. Hardware timer
7. Head voltage abnormality detection	

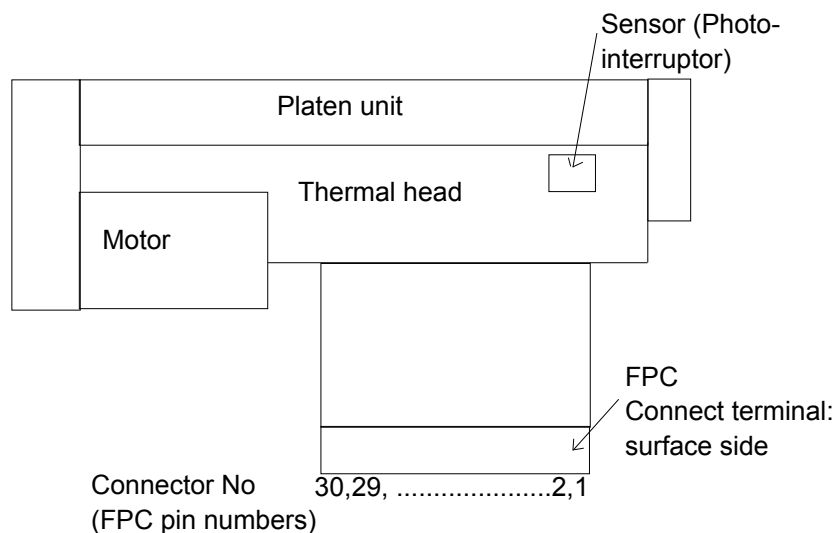

Архангельск (8182)63-90-72	Ижевск (3412)26-03-58	Магнитогорск (3519)55-03-13	Пермь (342)205-81-47	Сургут (3462)77-98-35
Астана (7172)727-132	Иркутск (395)279-98-46	Москва (495)268-04-70	Ростов-на-Дону (863)308-18-15	Тверь (4822)63-31-35
Астрахань (8512)99-46-04	Казань (843)206-01-48	Мурманск (8152)59-64-93	Рязань (4912)46-61-64	Томск (3822)98-41-53
Барнаул (3852)73-04-60	Калининград (4012)72-03-81	Набережные Челны (8552)20-53-41	Самара (846)206-03-16	Тула (4872)74-02-29
Белгород (4722)40-23-64	Калуга (4842)92-23-67	Нижний Новгород (831)429-08-12	Санкт-Петербург (812)309-46-40	Тюмень (3452)66-21-18
Брянск (4832)59-03-52	Кемерово (3842)65-04-62	Новокузнецк (3843)20-46-81	Саратов (845)249-38-78	Ульяновск (8422)24-23-59
Владивосток (423)249-28-31	Киров (8332)68-02-04	Новосибирск (383)227-86-73	Севастополь (8692)22-31-93	Уфа (347)229-48-12
Волгоград (844)278-03-48	Краснодар (861)203-40-90	Омск (3812)21-46-40	Симферополь (3652)67-13-56	Хабаровск (4212)92-98-04
Вологда (8172)26-41-59	Красноярск (391)204-63-61	Орел (4862)44-53-42	Смоленск (4812)29-41-54	Челябинск (351)202-03-61
Воронеж (473)204-51-73	Курск (4712)77-13-04	Оренбург (3532)37-68-04	Сочи (862)225-72-31	Череповец (8202)49-02-64
Екатеринбург (343)384-55-89	Липецк (4742)52-20-81	Пенза (8412)22-31-16	Ставрополь (8652)20-65-13	Ярославль (4852)69-52-93
Иваново (4932)77-34-06	Киргизия (996)312-96-26-47	Казахстан (772)734-952-31	Таджикистан (992)427-82-92-69	