



Низковольтные термопечатающие механизмы FTP-628 MCL101/103 Технические характеристики

Архангельск (8182)63-90-72	Ижевск (3412)26-03-58	Магнитогорск (3519)55-03-13	Пермь (342)205-81-47	Сургут (3462)77-98-35
Астана (7172)727-132	Иркутск (395)279-98-46	Москва (495)268-04-70	Ростов-на-Дону (863)308-18-15	Тверь (4822)63-31-35
Астрахань (8512)99-46-04	Казань (843)206-01-48	Мурманск (8152)59-64-93	Рязань (4912)46-61-64	Томск (3822)98-41-53
Барнаул (3852)73-04-60	Калининград (4012)72-03-81	Набережные Челны (8552)20-53-41	Самара (846)206-03-16	Тула (4872)74-02-29
Белгород (4722)40-23-64	Калуга (4842)92-23-67	Нижний Новгород (831)429-08-12	Санкт-Петербург (812)309-46-40	Тюмень (3452)66-21-18
Брянск (4832)59-03-52	Кемерово (3842)65-04-62	Новокузнецк (3843)20-46-81	Саратов (845)249-38-78	Ульяновск (8422)24-23-59
Владивосток (423)249-28-31	Киров (8332)68-02-04	Новосибирск (383)227-86-73	Севастополь (8692)22-31-93	Уфа (347)229-48-12
Волгоград (844)278-03-48	Краснодар (861)203-40-90	Омск (3812)21-46-40	Симферополь (3652)67-13-56	Хабаровск (4212)92-98-04
Вологда (8172)26-41-59	Красноярск (391)204-63-61	Орел (4862)44-53-42	Смоленск (4812)29-41-54	Челябинск (351)202-03-61
Воронеж (473)204-51-73	Курск (4712)77-13-04	Оренбург (3532)37-68-04	Сочи (862)225-72-31	Череповец (8202)49-02-64
Екатеринбург (343)384-55-89	Липецк (4742)52-20-81	Пенза (8412)22-31-16	Ставрополь (8652)20-65-13	Ярославль (4852)69-52-93
Иваново (4932)77-34-06	Киргизия (996)312-96-26-47	Казахстан (772)734-952-31	Таджикистан (992)427-82-92-69	

Единый адрес для всех регионов: fst@nt-rt.ru || www.fujitsu.nt-rt.ru

BATTERY DRIVE, FTP-608 Series

2" HIGH SPEED THERMAL PRINTER

FTP-628 MCL101/103, Easy Loading Method

■ OVERVIEW

The easy loading FTP-608 MCL Series is ultra compact high speed, battery driven thermal printer, printing on 2-inch wide paper (58mm) where platens are removable. Our original platen removal mechanism improved paper loading and maintenance.

The FTP-608 MCL series can be used for a variety of applications, such as portable terminals, POS, ticket issuing terminals, label printers, banking terminals, and measurement and medical equipment.

■ HIGHLIGHTS

- **Easy loading type**
Our original platen removal mechanism improved paper loading and maintenance.
- **Ultra compact**
Height 15.5 mm, width 70.3 mm, depth 33.0 mm for the 2 inch model.
- **High speed printing**
It can print at 80 mm/s (640 dotlines/s) maximum by using Fujitsu's unique head drive control.
- **High resolution printing**
8 dots/mm of resolution printing is possible.
- **RoHS compliant**



FTP-628MCL101/103

■ PART NUMBERS

Item		Part Number
Printer mechanism		FTP-628MCL101 (2-inch wide paper: 58mm) without platen open detect switch FTP-628MCL103 (2-inch wide paper: 58mm) with platen open detect switch FTP-628MCL103#70 (2-inch wide paper: 58mm) with platen open detect switch
LSI for driving		FTP-628CU301 R (ANK only) FTP-628CU601R
Interface Board	Parallel	FTP-628DCL300 (Centronics)
	Serial	FTP-628DSL305 (RS 232C) FTP-628DSL603 (High-speed RS232C)
	USB	FTP-628DSL602 (V2.0)
Interface Cables	Parallel	FTP-628Y202
	Serial	FTP-628Y302
	USB	FTP-629Y301
Power cable	Head, motor, logic	FTP-628Y402

■ SPECIFICATIONS

Item	Specifications
Part number	FTP-628MCL101/103
Printing method	Thermal-line dot method
Dot structure	384 dots/line
Dot pitch (Horizontal)	0.125 mm (8 dots/mm)—Dot density
Dot pitch (Vertical)	0.125 mm (8 dots/mm)—Line feed pitch
Effective printing area	48 mm
Number of columns	ANK 32 columns/line (maximum 12x 24 dot font)
Paper width	58 mm ⁺⁰ -1
Paper thickness	60 to 100 μ m (some paper in this range may not be used because of paper characteristics)
Printing Speed	Maximum 80mm/sec. (640 dot line/sec.) at 8.5V
Character types	Alphanumeric, katakana: 159 types International and special characters: 195 types JIS Kanji level 1, level 2, non-Kanji (supported only when Kanji CG is mounted): about 6800 types
Character, dimensions (H×W), number of columns	12 × 24 dots, (1.5 × 3.0mm), 32 columns: ANK 24 × 24 dots, (3.0 × 3.0mm), 16 columns: ANK, Kanji 8 × 16 dots, (1.0 × 2.0 mm), 48 columns: ANK 16 × 16 dots, (2.0 × 2.0 mm), 24 columns: ANK, Kanji

FTP-628MCL101/103

■ SPECIFICATIONS

Item		Specification
		FTP-628MCL101/103
Interface		Conforms to RS232C / Centronics
Operating Voltage	For print head	4.2 VDC to 8.5 V, average current 0.87A (0.93), peak value Printing ratio: 12.5%, printing speed 50mm/sec. at 7.2 V
	For motor	4.2 VDC to 8.5 V, 1 A maximum
	For logic	3.0 to 5.25VDC, 0.1 A maximum
Dimensions	Printer mechanism	70.2 x 33.0 x 15.5 mm (WxDxH)
	Interface board	69.3 x 52 x 15mm (WxDxH)
Weight	Printer mechanism	Approximately 42 g
	Interface board	Approximately 20g
Head life		Pulse resistance: 100 million pulses/dot (under our standard conditions). Abrasion resistance: paper traveling distance 50km (print ratio: 25% or less)
Operating environment	Operating temperature*	0° C to +50° C
	Operating humidity	20 to 85% RH (no condensation)
	Storage temperature	-20° C to +60° C (paper not included)
	Storage humidity	5 to 90% RH (no condensation)
Detection function	Head temperature detection	Detected by thermistor
	Paper out/mark detection	Detected by photo-interrupter
Recommended thermal sensitive paper		High sensitive paper: TF50KS-E4 (Nippon Paper)
		Standard paper: TK50KS-E (Nippon Paper) PD150R (Oji Paper) FTP-020P0701 (58mm)
		Medium life storage paper: TK60KS-F1 (Nippon Paper) FTP-020P0102 (58mm) PD170R (Oji Paper) AFP220VBB-1 (Mitsubishi Paper)
		Long life storage paper: PD160R-N (Oji Paper) AFP-235 (Mitsubishi Paper) TP50KJ-R (Nippon Paper) HA112AA (Nippon Paper)

*+5°C to +40°C printing density assurance range (-25 to 70°C capability)

FTP-628MCL101/103

FUNCTION

Item	Item	Item
1. Test print function	8. Mark detection function	
2. Paper out detection	9. MCU operation abnormality detection	
3. Paper near end detection	10. Power ON/OFF sequence protection	
4. Thermal head temperature abnormality detection	11. Motor over-current protection	
5. Blow-out fuse detection	12. Hardware timer	
6. Head voltage abnormality detection		
7. Motor power saving function		

DIMENSIONS

1. Printer mechanism: 2- inch

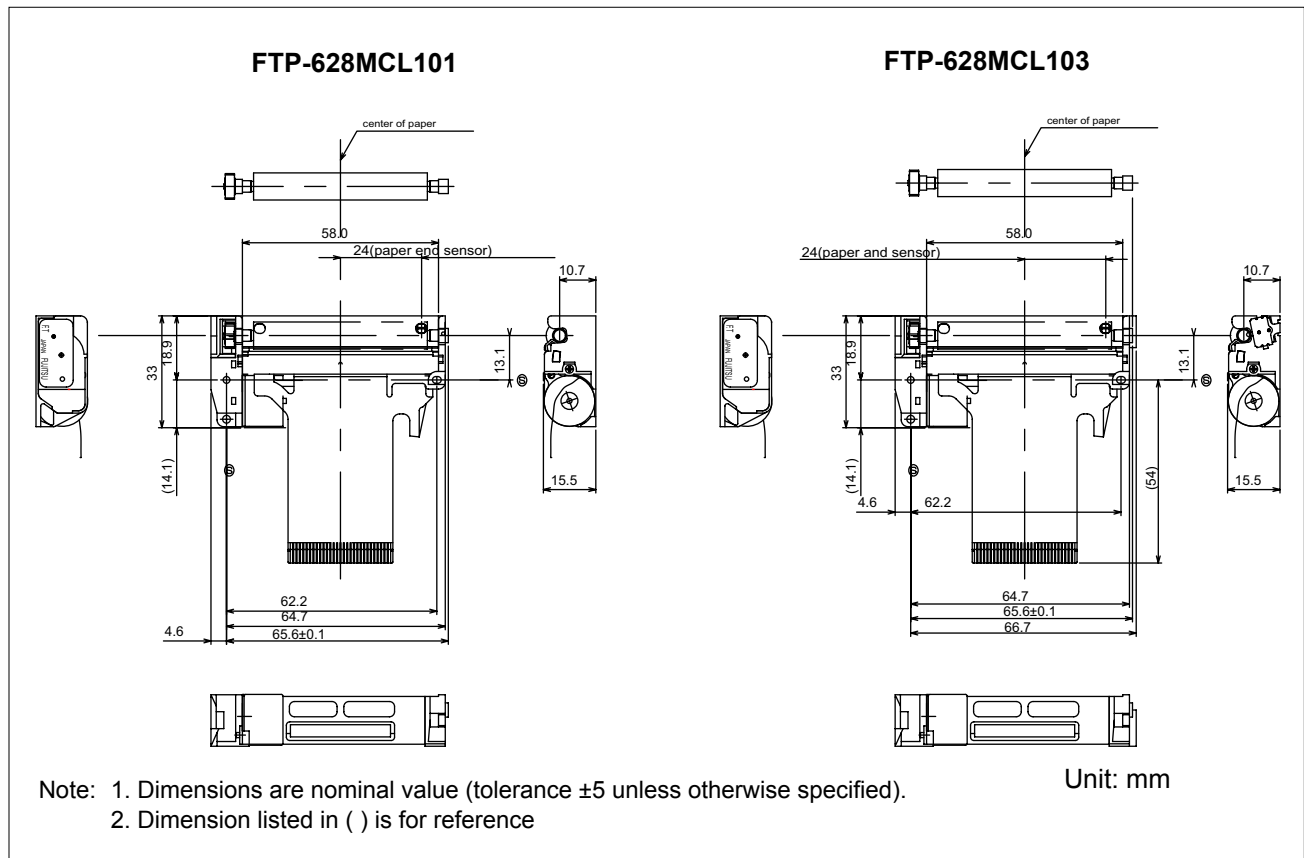

■ PRINTER CONNECTOR (FLEXIBLE PT BOARD) PIN ARRAYS FTP-628 MCL101/103

Thermal head, control circuit side connector: 52610-3071Molex or equivalent product

No	Signal	I/O	Contents
1	PHK	—	Cathode for photo interruptor
2	VSEN	I	paper sensor power
3	PHE	O	Emittor for photo interruptor
4	N.C. (101)/ SW1 (103)	—/I	Platen release switch
5	N.C. (101)/ SW2 (103)	—/I	Platen release switch
6	VH	I	Head drive power
7	VH	I	
8	DI	I	Data in
9	CLK	I	Synchronous clock for communication
10	GND	—	Ground power supply for thermal head
11	GND	—	
12	STB6	I	Thermal head energizing control signal
13	STB5	I	
14	STB4	I	
15	VDD	I	Logic power
16	TH	O	Thermally sensitive resistor input termnial 1
17	TH	O	Thermally sensitive resistor input termnial 2
18	STB3	I	Thermal head energizing control signal
19	STB2	I	
20	STB1	I	
21	GND	—	Ground power supply for thermal head
22	GND	—	
23	LAT	I	Data latch
24	DO	O	Data out
25	VH	I	Power supply for thermal head
26	VH	I	
27	MT A	I	Stepping motor excitation signal
28	MT \bar{A}	I	
29	MT B	I	
30	MT \bar{B}	I	

Do not plug or unplug the FPC when power is on.

Архангельск (8182)63-90-72	Ижевск (3412)26-03-58	Магнитогорск (3519)55-03-13	Пермь (342)205-81-47	Сургут (3462)77-98-35
Астана (7172)727-132	Иркутск (395)279-98-46	Москва (495)268-04-70	Ростов-на-Дону (863)308-18-15	Тверь (4822)63-31-35
Астрахань (8512)99-46-04	Казань (843)206-01-48	Мурманск (8152)59-64-93	Рязань (4912)46-61-64	Томск (3822)98-41-53
Барнаул (3852)73-04-60	Калининград (4012)72-03-81	Набережные Челны (8552)20-53-41	Самара (846)206-03-16	Тула (4872)74-02-29
Белгород (4722)40-23-64	Калуга (4842)92-23-67	Нижний Новгород (831)429-08-12	Санкт-Петербург (812)309-46-40	Тюмень (3452)66-21-18
Брянск (4832)59-03-52	Кемерово (3842)65-04-62	Новокузнецк (3843)20-46-81	Саратов (845)249-38-78	Ульяновск (8422)24-23-59
Владивосток (423)249-28-31	Киров (8332)68-02-04	Новосибирск (383)227-86-73	Севастополь (8692)22-31-93	Уфа (347)229-48-12
Волгоград (844)278-03-48	Краснодар (861)203-40-90	Омск (3812)21-46-40	Симферополь (3652)67-13-56	Хабаровск (4212)92-98-04
Вологда (8172)26-41-59	Красноярск (391)204-63-61	Орел (4862)44-53-42	Смоленск (4812)29-41-54	Челябинск (351)202-03-61
Воронеж (473)204-51-73	Курск (4712)77-13-04	Оренбург (3532)37-68-04	Сочи (862)225-72-31	Череповец (8202)49-02-64
Екатеринбург (343)384-55-89	Липецк (4742)52-20-81	Пенза (8412)22-31-16	Ставрополь (8652)20-65-13	Ярославль (4852)69-52-93
Иваново (4932)77-34-06	Киргизия (996)312-96-26-47	Казахстан (772)734-952-31	Таджикистан (992)427-82-92-69	

Единый адрес для всех регионов: fst@nt-rt.ru || www.fujitsu.nt-rt.ru