



Высокоскоростные термопечатающие механизмы FTP-629MCL103, FTP-629MCL383-R

Технические характеристики

Архангельск (8182)63-90-72	Ижевск (3412)26-03-58	Магнитогорск (3519)55-03-13	Пермь (342)205-81-47	Сургут (3462)77-98-35
Астана (7172)727-132	Иркутск (395)279-98-46	Москва (495)268-04-70	Ростов-на-Дону (863)308-18-15	Тверь (4822)63-31-35
Астрахань (8512)99-46-04	Казань (843)206-01-48	Мурманск (8152)59-64-93	Рязань (4912)46-61-64	Томск (3822)98-41-53
Барнаул (3852)73-04-60	Калининград (4012)72-03-81	Набережные Челны (8552)20-53-41	Самара (846)206-03-16	Тула (4872)74-02-29
Белгород (4722)40-23-64	Калуга (4842)92-23-67	Нижний Новгород (831)429-08-12	Санкт-Петербург (812)309-46-40	Тюмень (3452)66-21-18
Брянск (4832)59-03-52	Кемерово (3842)65-04-62	Новокузнецк (3843)20-46-81	Саратов (845)249-38-78	Ульяновск (8422)24-23-59
Владивосток (423)249-28-31	Киров (8332)68-02-04	Новосибирск (383)227-86-73	Севастополь (8692)22-31-93	Уфа (347)229-48-12
Волгоград (844)278-03-48	Краснодар (861)203-40-90	Омск (3812)21-46-40	Симферополь (3652)67-13-56	Хабаровск (4212)92-98-04
Вологда (8172)26-41-59	Красноярск (391)204-63-61	Орел (4862)44-53-42	Смоленск (4812)29-41-54	Челябинск (351)202-03-61
Воронеж (473)204-51-73	Курск (4712)77-13-04	Оренбург (3532)37-68-04	Сочи (862)225-72-31	Череповец (8202)49-02-64
Екатеринбург (343)384-55-89	Липецк (4742)52-20-81	Пенза (8412)22-31-16	Ставрополь (8652)20-65-13	Ярославль (4852)69-52-93
Иваново (4932)77-34-06	Киргизия (996)312-96-26-47	Казахстан (772)734-952-31	Таджикистан (992)427-82-92-69	

Единый адрес для всех регионов: fst@nt-rt.ru || www.fujitsu.nt-rt.ru

24V DRIVE, FTP-609 SERIES ULTRA HIGH SPEED (200mm/s) 2" TYPE MECHANISM (Cutter option)

FTP-629MCL103/383-R

■ OVERVIEW

The FTP-609MCL Series thermal printer (driven by 24VDC) provides ultra-high speed printing (200mm/s) for 2-inch and 3-inch wide paper.

This series is suitable for a variety of applications, such as POS/ ECR, kiosk terminals, ticket machines, label printers, banking machines, measuring devices, medical equipment, etc.

■ HIGHLIGHTS

- **Ultra high speed printing**
It can print at 200 mm/s (1600 dotlines/s) maximum by using Fujitsu Components' unique head drive control.
- **High resolution**
8 dots/mm head provides clear print out.
- **ELM (Easy Loading Mechanism) with lock type**
Fujitsu Components' unique platen release mechanism allows easy paper setting and easy head maintenance.
- **Auto Cutter**
Printer with auto cutter (full cut/ partial cut) is available. It can be mounted on top of the mechanism.
- **Multi-featuring diecast frame**
By application of multi-featuring diecast frame, continuous print by function of heat-sink, high ESD stand by function of earth frame and shock/vibration stand by function of solid frame are valid.
- **Compact size**
Depth: 40.5mm, width: 82.2mm, height: 20.5mm for the 2-inch model. The 3-inch model has a width of 104.2mm
- **RoHS compliant**

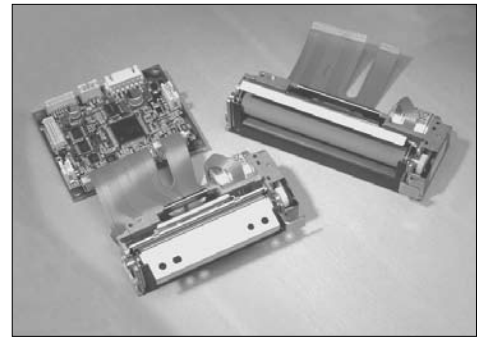

FTP-6x9MCL103R with FTP-629DCL034R

FTP-629MCL103/383-R

■ PART NUMBERS

Name		Part Number		
Printer mechanism	Detachable platen	FTP-629MCL103R	FTP-629MCL105R	FTP-629MCL103R
Mechanism with cutter	Detachable platen	FTP-629MCL383#01/#02-R	FTP-629MCL385R	FTP-629MCL383#01/#02-R
LSI		FTP-629CU101R	FTP-629SR201	FTP-629CU301R
Interface board	Parallel	FTP-629DCL014R	FTP-629DSL181R*	
	Serial (RS232C)	FTP-629DSL034R	FTP-629DSL181R*	FTP-629DSL301R
	USB	---	FTP-629DSL112R	FTP-629DSL301R
Thermal head cable extension		---	FTP-629Y001	---
Interface cable (board to mechanism)	Parallel	FTP-628Y202		---
	Serial	FTP-628Y302	FTP-629Y302	
	USB	---	FTP-629Y301	
Power supply cable	Logic	FTP-629Y401	---	---
	Head, motor	FTP-629Y601		FTP-629Y602

*1: #01 is for full cut, #02 is for partial cut

*2: Interface is selectable by DIP switch

■ GENERAL SPECIFICATIONS

Item		Specifications	
Part number		FTP-629MCL103/105-R	FTP-629MCL383/385#01/#02-R
Printing method		Thermal sensitive line dot method	
Dot structure		432 dots/line	
Dot pitch (horizontal)		0.125mm (8dots/mm) - Dot density	
Dot pitch (vertical)		0.125mm (8dots/mm) - Line feed pitch	
Effective printing area		54 mm	
Number of columns		ANK 36 columns/line (12 x 24 dot font) OCR 18 columns	
Paper width		58mm +0/-1	
Paper thickness		60 to 100µm (there may be exceptions)	60 to 100µm
Cutting type		---	full or partial
Printing speed	FTP-629DCL/DSL series	80mm/sec. (640 dot lines/sec.) line mode 200mm/sec. (1600 dot lines/sec.) image mode	
	FTP-629DSL100 series FTP-629DSL300 series	125mm/sec. (1000 dot lines/sec.) line mode 200mm/sec. (1600 dot lines/sec.) page mode	
Character types	Alphanumeric, Kana:	159 types	159 types
	International	195 types	195 types
	JIS Kanji (Kanji CG loaded board)	about 6,800 types	about 6,800 types
	OCR I		103 types
	OCR III		23 types
	OCR IV		103 types
Extended numeric		11 types	
Character, dimensions (WxH), number of columns	24x12 dots, (3.0x1.5mm)	36 columns	18 columns, OCR I
	16x16 dots, (2.0x2.0mm)	18 columns	18 columns, OCR III
	24x24 dots, (3.0x3.0mm)	54 columns	12 columns, OCR IV
	8x16 dots, (1.0x4.0mm)	27 columns	18 columns, extended numeric
Interface standard		Centronics / RS232C / USB	Serial/USB

FTP-629MCL103/383-R

(Continued)

Item	Specifications	
Part number	FTP-629MCL103/105-R	FTP-629MCL383#01/#02-R
Power supply	For head	24 VDC \pm 5%, 1.4A (3A) (24V, 25% printing ratio)
	For printer motor	24 VDC \pm 5% 1A maximum
	For cutter motor	--- 24 VDC \pm 5% 1A maximum
	For logic	5 VDC \pm 5% 0.2A maximum
Dimension W x D x H	Printer mechanism	82.5 x 40.5 x 20.5mm ---
	Printer mechanism with cutter	--- 90.5 x 70.3 x 37.4mm
	Interface board (DCL/DSL)	70 x 60 x 21.6mm
	Interface board (DSL100)	95.1 x 73.5 x 11.6mm
	Interface board (DSL300)	77 x 50 x 21.5mm
Weight	Printer mechanism	Approximately 100/110g ---
	Printer mechanism with cutter	--- Approximately 290g
	Interface board (standard speed)	Approximately 25g
	Interface board (medium speed)	Approximately 45 g
	Interface board (high speed)	Approximately 20g
Life	Head	Pulse durability: 100 million pulse/dot (using Fujitsu's standard driving method) Wear resistance: 100km (at 12.5% print ratio)
	Cutter	--- 1,00,000 cuts minimum
	Platen	5,000 times (open/close)
Environmental conditions	Operating temperature	-10°C to +60°C (guarantee) 0°C to +50°C
	Operating humidity	20 to 85% RH (no condensation)
	Storage temperature	-40°C to +70°C -20°C to +60°C
	Storage humidity	5 to 95% RH (no condensation)
Detection	Head temperature	By thermistor
	Paper out/Mark detect	By photointerruptor
	Head release	By slide switch
Recommended thermal sensitive paper	High sensitive paper	TF50KS-E4 (Nippon paper)
	Standard paper	TF60KS-E2 (Nippon paper), FTP-020P0104 (58mm) PD150R (Oji paper), FTP-020P0701 (58mm)
	Medium life storage paper	TF60KS-F1 (Nippon paper), FTP-020P0102 (58mm) PD170R (Oji paper) P220VBB-1 (Mitsubishi paper) PD160R-N (Oji paper)
	Long life storage paper	AFP-235 (Mitsubishi paper) TP50KJ-R (Nippon paper) HA220AA (Nippon paper)

FUNCTION

	ITEM		ITEM
1.	Test printing	8.	Cutter trouble detection
2.	Paper-out detection	9.	Motor power save
3.	Paper near end detection	10.	Mark detection
4.	Head-up detection	11.	MCU trouble detection
5.	Abnormal temp. of thermal head detection	12.	Power on/off sequence protection
6.	Blown fuse detection	13.	Motor protection
7.	Abnormal voltage detection of head	14.	Hardware timer

DIMENSIONS

1. Printer mechanism

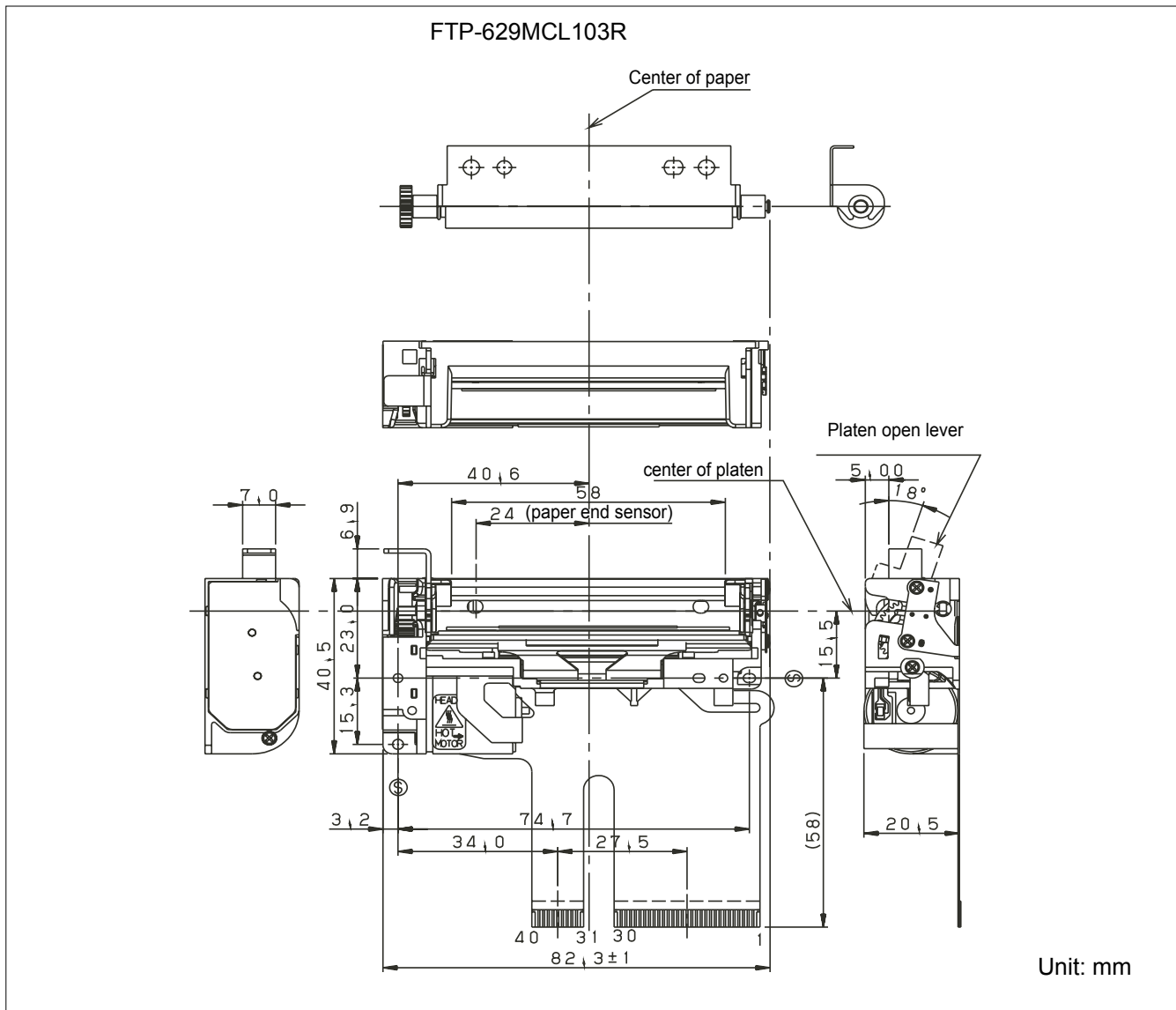

2. Printer mechanism

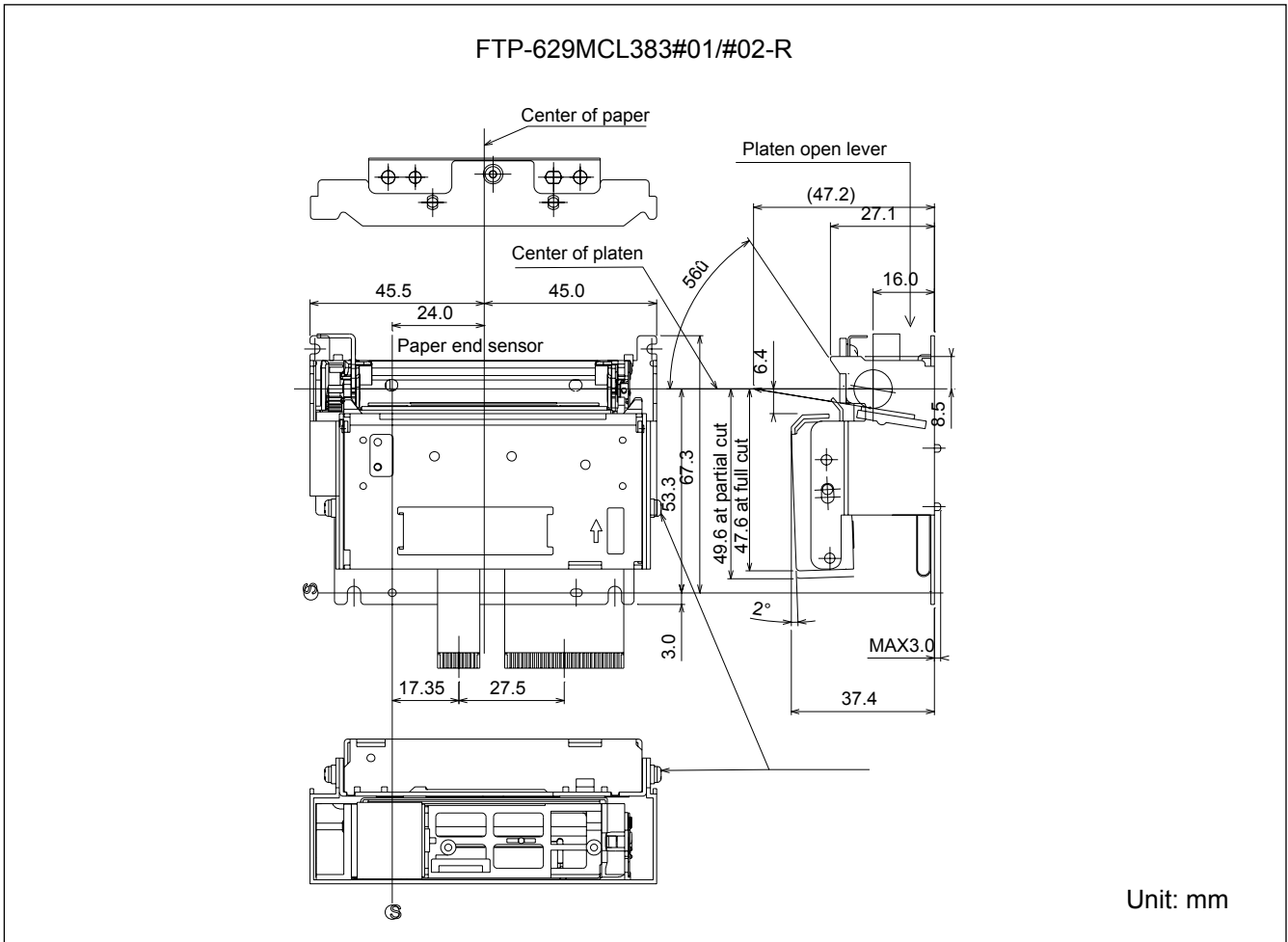

■ CONNECTOR PIN ASSIGNMENT OF PRINTER MECHANISM (FPC)

1. Thermal head control circuit side (CN3)

Part number : 52610-3071 (Molex) or equivalent

No	Signal	I/O	Contents	No	Signal	I/O	Contents
1	SW	-	Platen open switch	2	SW	-	Platen open switch
3	VH		Power for thermal head	4	VH		Power for thermal head
5	VH		Power for thermal head	6	VH		Power for thermal head
7	DI	I	Data in	8	$\overline{\text{STB2}}$	I	Print enable 2
9	$\overline{\text{STB3}}$	I	Print enable 3	10	VDD	-	Power for logic
11	TM	O	Thermistor	12	GND	-	Head GND
13	GND	-	Head GND	14	GND	-	Head GND
15	GND	-	Head GND	16	GND	-	Head GND
17	GND	-	Head GND	18	GND	-	Head GND
19	GND	-	Head GND	20	GND	-	Head GND
21	TH	O	Thermistor	22	STB1	I	Print enable 1
23	NC	-	Not connected	24	LAT	I	Print data latch
25	CLK	I	Clock	26	DO	O	Data output
27	VH		Power for thermal head	28	VH		Power for thermal head
29	VH		Power for thermal head	30	VH		Power for thermal head

2. Motor, Sensor (CN4)

Connector on circuit side : 52610-1071 (Molex) or equivalent

No.	Signal	I/O	Contents	No.	Signal	I/O	Contents
31	NC	-	Not connected	32	TM	O	Motor temperature sensor
33	TM	-	Motor temperature sensor	34	MT \bar{A}	I	Motor coil excitation /A
35	MT A	I	Motor coil excitation A	36	MT \bar{B}	I	Motor coil excitation /B
37	MT B	I	Motor coil excitation B	38	PHK	-	Paper out sensor cathode
39	VSE	-	Power for paper sensor	40	$\overline{\text{PHE}}$	O	Paper out sensor emitter

3. Cutter (CN5)

Connector type: B4B-PH-SM4 TB (J.S.T.) or equivalent

No.	Signal	I/O	Contents	No.	Signal	I/O	Contents
1	SW1	-	Cutter home position switch	2	SW2	O	Cutter home position switch
3	M+	O	Cutter motor drive	4	M-	I	Cutter motor drive

■ INTERFACE, COMMAND, OPTIONS

Please refer to the FTP-629DCL/DSL, FTP-629DCL/DSL100, FTP-629DSL300 series datasheet.

Архангельск (8182)63-90-72	Ижевск (3412)26-03-58	Магнитогорск (3519)55-03-13	Пермь (342)205-81-47	Сургут (3462)77-98-35
Астана (7172)727-132	Иркутск (395)279-98-46	Москва (495)268-04-70	Ростов-на-Дону (863)308-18-15	Тверь (4822)63-31-35
Астрахань (8512)99-46-04	Казань (843)206-01-48	Мурманск (8152)59-64-93	Рязань (4912)46-61-64	Томск (3822)98-41-53
Барнаул (3852)73-04-60	Калининград (4012)72-03-81	Набережные Челны (8552)20-53-41	Самара (846)206-03-16	Тула (4872)74-02-29
Белгород (4722)40-23-64	Калуга (4842)92-23-67	Нижний Новгород (831)429-08-12	Санкт-Петербург (812)309-46-40	Тюмень (3452)66-21-18
Брянск (4832)59-03-52	Кемерово (3842)65-04-62	Новокузнецк (3843)20-46-81	Саратов (845)249-38-78	Ульяновск (8422)24-23-59
Владивосток (423)249-28-31	Киров (8332)68-02-04	Новосибирск (383)227-86-73	Севастополь (8692)22-31-93	Уфа (347)229-48-12
Волгоград (844)278-03-48	Краснодар (861)203-40-90	Омск (3812)21-46-40	Симферополь (3652)67-13-56	Хабаровск (4212)92-98-04
Вологда (8172)26-41-59	Красноярск (391)204-63-61	Орел (4862)44-53-42	Смоленск (4812)29-41-54	Челябинск (351)202-03-61
Воронеж (473)204-51-73	Курск (4712)77-13-04	Оренбург (3532)37-68-04	Сочи (862)225-72-31	Череповец (8202)49-02-64
Екатеринбург (343)384-55-89	Липецк (4742)52-20-81	Пенза (8412)22-31-16	Ставрополь (8652)20-65-13	Ярославль (4852)69-52-93
Иваново (4932)77-34-06	Киргизия (996)312-96-26-47	Казахстан (772)734-952-31	Таджикистан (992)427-82-92-69	

Единый адрес для всех регионов: fst@nt-rt.ru || www.fujitsu.nt-rt.ru