



# Высокоскоростные термопечатающие механизмы FTP-62GMCL153, FTP-62GMCL453

## Технические характеристики

Архангельск (8182)63-90-72	Ижевск (3412)26-03-58	Магнитогорск (3519)55-03-13	Пермь (342)205-81-47	Сургут (3462)77-98-35
Астана (7172)727-132	Иркутск (395)279-98-46	Москва (495)268-04-70	Ростов-на-Дону (863)308-18-15	Тверь (4822)63-31-35
Астрахань (8512)99-46-04	Казань (843)206-01-48	Мурманск (8152)59-64-93	Рязань (4912)46-61-64	Томск (3822)98-41-53
Барнаул (3852)73-04-60	Калининград (4012)72-03-81	Набережные Челны (8552)20-53-41	Самара (846)206-03-16	Тула (4872)74-02-29
Белгород (4722)40-23-64	Калуга (4842)92-23-67	Нижний Новгород (831)429-08-12	Санкт-Петербург (812)309-46-40	Тюмень (3452)66-21-18
Брянск (4832)59-03-52	Кемерово (3842)65-04-62	Новокузнецк (3843)20-46-81	Саратов (845)249-38-78	Ульяновск (8422)24-23-59
Владивосток (423)249-28-31	Киров (8332)68-02-04	Новосибирск (383)227-86-73	Севастополь (8692)22-31-93	Уфа (347)229-48-12
Волгоград (844)278-03-48	Краснодар (861)203-40-90	Омск (3812)21-46-40	Симферополь (3652)67-13-56	Хабаровск (4212)92-98-04
Вологда (8172)26-41-59	Красноярск (391)204-63-61	Орел (4862)44-53-42	Смоленск (4812)29-41-54	Челябинск (351)202-03-61
Воронеж (473)204-51-73	Курск (4712)77-13-04	Оренбург (3532)37-68-04	Сочи (862)225-72-31	Череповец (8202)49-02-64
Екатеринбург (343)384-55-89	Липецк (4742)52-20-81	Пенза (8412)22-31-16	Ставрополь (8652)20-65-13	Ярославль (4852)69-52-93
Иваново (4932)77-34-06	Киргизия (996)312-96-26-47	Казахстан (772)734-952-31	Таджикистан (992)427-82-92-69	

Единый адрес для всех регионов: [fst@nt-rt.ru](mailto:fst@nt-rt.ru) || [www.fujitsu.nt-rt.ru](http://www.fujitsu.nt-rt.ru)

# FUJITSU Component Thermal Printer FTP-62GMCL153/453 series

Fujitsu 2" high speed (200mm/s) thermal printer mechanism

## Overview

The compact, ultra low profile design FTP-62GMCL series thermal printer (driven by 24VDC) provides high speed printing (200mm/s) for 2-inch wide paper.

The series is suitable for a variety of applications, such as POS/ECR, kiosk terminals, ticket machines, label printers, banking machines, measuring devices, medical equipment, etc.

## Features

- **High-speed printing**  
It can print at 200mm/s (1600 dotlines/s) maximum by using Fujitsu Components' unique head drive control
- **Rear paper insertion mechanism with lock type**  
Fujitsu Components' unique platen release mechanism allows for a straight paper path and easy head maintenance
- **Auto cutter**  
Optional ultra-low profile auto cutter (full/partial cut) comes mounted from the factory (FTP-62GMCL453)
- **Multi-feature diecast frame**  
The rugged die-cast frame provides excellent ESD performance, is shock/vibration resistant and the heat-sink allows for continuous printing
- **Compact size**  
Depth: 20.4mm, width: 76.2mm, height: 36.3mm (FTP-62GMCL153/#01)  
Depth: 34.8mm, width: 80.5mm, height: 45.6mm (FTP-62GMCL453)
- **High resolution**  
8 dots/mm head provides clear print out
- UL recognized, file # E171434
- RoHS compliant

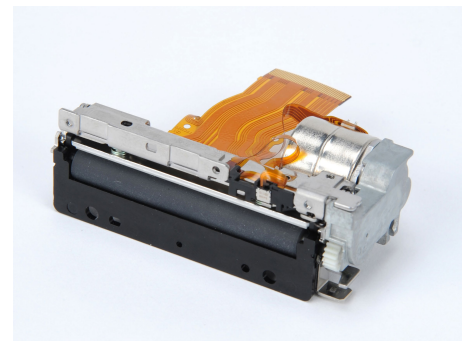

FTP-62GMCL153#01

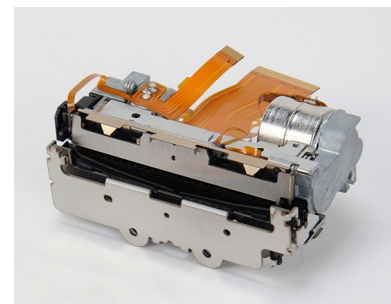

FTP-62GMCL453

## ■ Part numbers

Item		Part Number
Printer mechanism	Back insertion	FTP-62GMCL153 (58mm paper width)
		FTP-62GMCL153#01 (60mm paper width)
Printer mechanism with cutter	Back insertion	FTP-62GMCL453 (58mm paper width, with cutter)
Interface board	Serial (RS232C, USB)	FTP-62GDSL001#01 (Japanese font)
	Serial (RS232C, USB)	FTP-62GDSL001#02 (Traditional Chinese font)
Interface cable	Serial	FTP-62GY302
	USB	FTP-62GY301
Power supply cable	Logic, head, motor	FTP-62GY601

## ■ Specifications

Item	Specifications		
Part number	FTP-62GMCL153	FTP-62GMCL153#01	FTP-62GMCL453
Printing method	Thermal sensitive line dot method		
Dot structure	432 dots/lines		
Dot pitch (horizontal)	0.125mm (8 dots/mm) - Dot density		
Dot pitch (vertical)	0.125mm (8 dots/mm) - Line feed pitch		
Effective printing area	54mm		
Number of columns	ANK 36 columns/line		
Paper width	58mm +0/-1	60mm +0/-1	58mm +0/-1
Paper thickness	60-150 $\mu$ m*1	60-150 $\mu$ m*1	60-100 $\mu$ m*1
Cutting type	---	---	Full or partial
Printing speed	200mm/s (1600 dot lines/s)		
Character types	Alphanumeric KANA	159 types	
	International and special	195 types	
	OCR I	103 types	
	OCR III	23 types	
	OCR IV	103 types	
	Extended numeric	12 types	
	JIS KANJI level 1, 2, non-Kanji Traditional Chinese	JIS KANJI: approx. 6800 (FTP-628GDSL001#01) 13, 503 (FTP-62GDSL001#02)	
Character dimensions (W x H), number of characters	8 x 16 dots, 54 columns, ANK	24 x 40 dots, 18 columns, OCR I	
	12 x 24 dots, 36 columns, ANK	24 x 48 dots, 18 columns, OCR II	
	16 x 16 dots, 27 columns, ANK	36 x 60 dots, 12 columns, OCR IV	
	24 x 24 dots, 18 columns, ANK	24 x 48 dots, 18 columns, extended numeric	

\*1: there may be exceptions

Item	Specifications		
Part number	FTP-62GMCL153	FTP-62GMCL153#01	FTP-62GMCL453
Power	For head	24VDC $\pm$ 10% 2.8A (24V, 1500 $\Omega$ , +25°C, concurrent applied dot number: 176 dots)	
	For printer motor	24VDC $\pm$ 10% 0.6A maximum	
	For logic	3.3 to 5VDC $\pm$ 5% 0.1A maximum	
Dimensions (WxDxH)	Printer mechanism	76.2 x 36.3 x 20.4mm	80.5 x 45.6 x 34.8mm
	Interface board (DCL/DSL)	70 x 35mm	
Weight	Printer mechanism	70g	135g
	Interface board (DCL/DSL)	15g	
Expected life	Head	Pulse durability: 100 million pulse/dot (using Fujitsu Components' standard driving method) Wear resistance: 100km (at 12.5% print ratio)	
Cutter	---	---	500,000 cuts min.
Environmental conditions	Operating temperature	+5°C to +40°C (guarantee)	
	Operating humidity	20 to 85% RH (no condensation)	
	Storage temperature	-20°C to +60°C (excluding paper)	
	Storage humidity	5 to 95% RH (no condensation)	
Detection functions	Head temperature	By thermistor	
	Paper out/Mark detect	By photointerrupter	
	Head release	By slide switch	
Recommended thermal sensitive paper	High sensitive paper	TF50KS-E45 (Nippon paper)	
	Standard paper	TF-60KS-E (Nippon paper), FTP-020P0104 (58mm), PD150R (Oji paper), FTP-020P0701 (58mm)	
	Medium term paper	TF-60KS-F1 (Nippon paper), FTP-020P0102 (58mm) PD170R (Oji paper) P220VBB-1 (Mitsubishi paper)	
	Long term paper	PD160R (Oji paper)	

■ Dimensions

- Printer mechanism: 2-inch

FTP-62GMCL153/153#01

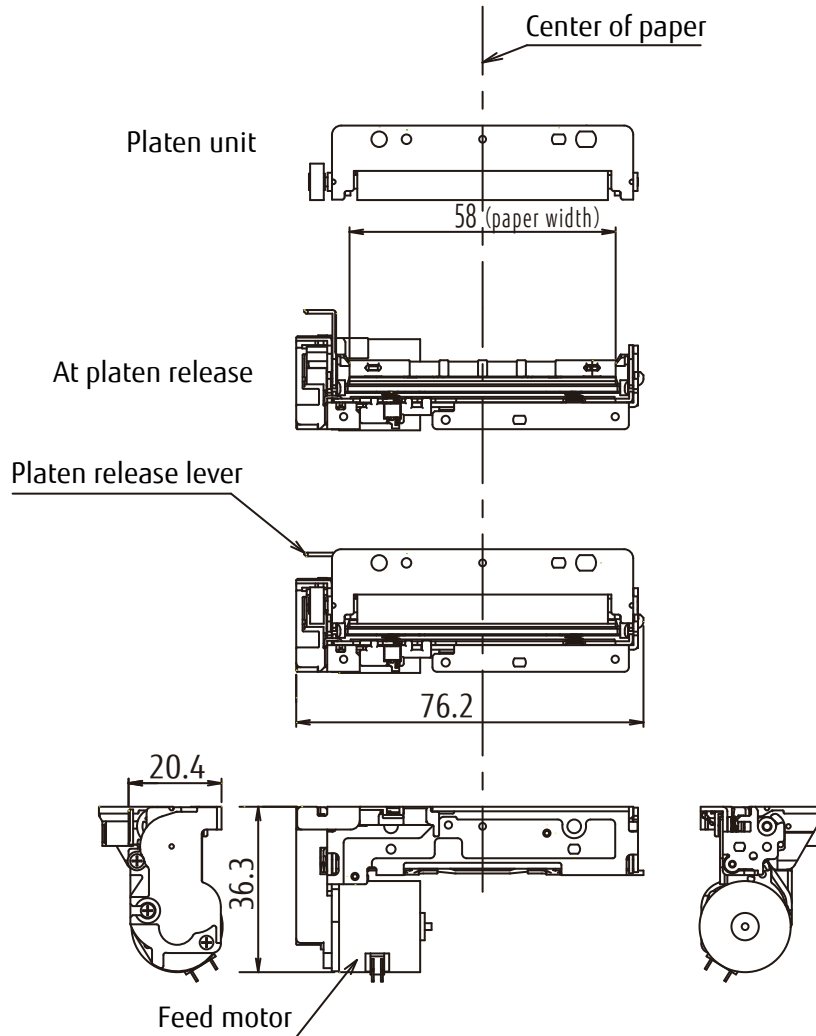

Note: 1. Dimensions are nominal value )tolerance  $\pm 0.5\text{mm}$  unless otherwise specified.  
2. Dimensions in ( ) is reference value.

■ Dimensions

- Printer mechanism: 2-inch, with cutter

FTP-62GMCL453

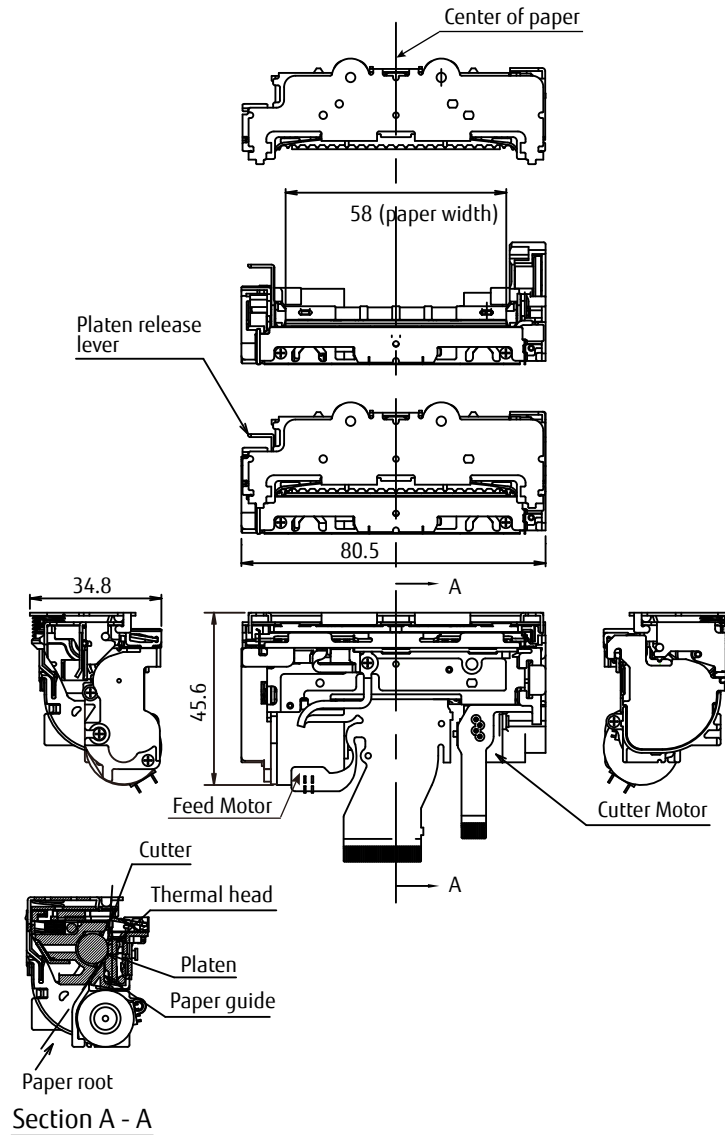

Note: 1. Dimensions are nominal value ) tolerance  $\pm 0.5\text{mm}$  unless otherwise specified.  
2. Dimensions in ( ) is reference value.

■ Connector pin assignments of printer mechanism (FPC)

No	Signal	Content	I/O
1	VSEN	Paper sensor power	IN
2	PHK	Cathode for photo interrupter	OUT
3	PHE	Emitter for photo interrupter	OUT
4	N.C.	Not connected	-
5	VH	Head drive power	IN
6	VH	Head drive power	IN
7	VH	Head drive power	IN
8	VH	Head drive power	IN
9	DI	Data in	IN
10	/STB2	/Strobe2	IN
11	/STB3	/Strobe3	IN
12	VDD	Logic power	IN
13	GND	Head ground	-
14	GND	Head ground	-
15	GND	Head ground	-
16	GND	Head ground	-
17	GND	Head ground	-
18	GND	Head ground	-
19	GND	Head ground	-
20	GND	Head ground	-
21	TM	Thermistor	OUT
22	N.C.	Not connected	-
23	/STB1	/Strobe1	IN
24	/LAT	/Data latch	IN
25	CLK	Clock	IN
26	VH	Head drive power	IN
27	VH	Head drive power	IN
28	VH	Head drive power	IN
29	VH	Head drive power	IN
30	N.C.	Not connected	-
31	SW	Platen switch release	OUT
32	SW	Platen switch release	OUT
33	MT_/A	Excitation signal /A	SINK/SOURCE
34	MT_/A	Excitation signal /A	SINK/SOURCE
35	MT_A	Excitation signal A	SINK/SOURCE
36	MT_A	Excitation signal A	SINK/SOURCE
37	MT_/B	Excitation signal /B	SINK/SOURCE
38	MT_/B	Excitation signal /B	SINK/SOURCE
39	MT_B	Excitation signal B	SINK/SOURCE
40	MT_B	Excitation signal B	SINK/SOURCE

■ Connector pin assignments of cutter (FPC)

No	Signal	Content	I/O
1	MT_/B	Excitation signal B	SINK/SOURCE
2	MT_/B	Excitation signal B	SINK/SOURCE
3	MT_B	Excitation signal /B	SINK/SOURCE
4	MT_B	Excitation signal /B	SINK/SOURCE
5	MT_/A	Excitation signal A	SINK/SOURCE
6	MT_/A	Excitation signal A	SINK/SOURCE
7	MT_A	Excitation signal /A	SINK/SOURCE
8	MT_A	Excitation signal /A	SINK/SOURCE
9	N.C.	Not connected	-
10	VSEN	Paper sensor power	IN
11	PHE	Emitter for photo interrupter	OUT
12	PHK	Cathode for photo interrupter	OUT

<b>Архангельск</b> (8182)63-90-72	<b>Ижевск</b> (3412)26-03-58	<b>Магнитогорск</b> (3519)55-03-13	<b>Пермь</b> (342)205-81-47	<b>Сургут</b> (3462)77-98-35
<b>Астана</b> (7172)727-132	<b>Иркутск</b> (395)279-98-46	<b>Москва</b> (495)268-04-70	<b>Ростов-на-Дону</b> (863)308-18-15	<b>Тверь</b> (4822)63-31-35
<b>Астрахань</b> (8512)99-46-04	<b>Казань</b> (843)206-01-48	<b>Мурманск</b> (8152)59-64-93	<b>Рязань</b> (4912)46-61-64	<b>Томск</b> (3822)98-41-53
<b>Барнаул</b> (3852)73-04-60	<b>Калининград</b> (4012)72-03-81	<b>Набережные Челны</b> (8552)20-53-41	<b>Самара</b> (846)206-03-16	<b>Тула</b> (4872)74-02-29
<b>Белгород</b> (4722)40-23-64	<b>Калуга</b> (4842)92-23-67	<b>Нижний Новгород</b> (831)429-08-12	<b>Санкт-Петербург</b> (812)309-46-40	<b>Тюмень</b> (3452)66-21-18
<b>Брянск</b> (4832)59-03-52	<b>Кемерово</b> (3842)65-04-62	<b>Новокузнецк</b> (3843)20-46-81	<b>Саратов</b> (845)249-38-78	<b>Ульяновск</b> (8422)24-23-59
<b>Владивосток</b> (423)249-28-31	<b>Киров</b> (8332)68-02-04	<b>Новосибирск</b> (383)227-86-73	<b>Севастополь</b> (8692)22-31-93	<b>Уфа</b> (347)229-48-12
<b>Волгоград</b> (844)278-03-48	<b>Краснодар</b> (861)203-40-90	<b>Омск</b> (3812)21-46-40	<b>Симферополь</b> (3652)67-13-56	<b>Хабаровск</b> (4212)92-98-04
<b>Вологда</b> (8172)26-41-59	<b>Красноярск</b> (391)204-63-61	<b>Орел</b> (4862)44-53-42	<b>Смоленск</b> (4812)29-41-54	<b>Челябинск</b> (351)202-03-61
<b>Воронеж</b> (473)204-51-73	<b>Курск</b> (4712)77-13-04	<b>Оренбург</b> (3532)37-68-04	<b>Сочи</b> (862)225-72-31	<b>Череповец</b> (8202)49-02-64
<b>Екатеринбург</b> (343)384-55-89	<b>Липецк</b> (4742)52-20-81	<b>Пенза</b> (8412)22-31-16	<b>Ставрополь</b> (8652)20-65-13	<b>Ярославль</b> (4852)69-52-93
<b>Иваново</b> (4932)77-34-06	<b>Киргизия</b> (996)312-96-26-47	<b>Казахстан</b> (772)734-952-31	<b>Таджикистан</b> (992)427-82-92-69	