



Высокоскоростные термопечатающие механизмы FTP-639MCL353, FTP-639MCL354-R

Технические характеристики

Архангельск (8182)63-90-72	Ижевск (3412)26-03-58	Магнитогорск (3519)55-03-13	Пермь (342)205-81-47	Сургут (3462)77-98-35
Астана (7172)727-132	Иркутск (395)279-98-46	Москва (495)268-04-70	Ростов-на-Дону (863)308-18-15	Тверь (4822)63-31-35
Астрахань (8512)99-46-04	Казань (843)206-01-48	Мурманск (8152)59-64-93	Рязань (4912)46-61-64	Томск (3822)98-41-53
Барнаул (3852)73-04-60	Калининград (4012)72-03-81	Набережные Челны (8552)20-53-41	Самара (846)206-03-16	Тула (4872)74-02-29
Белгород (4722)40-23-64	Калуга (4842)92-23-67	Нижний Новгород (831)429-08-12	Санкт-Петербург (812)309-46-40	Тюмень (3452)66-21-18
Брянск (4832)59-03-52	Кемерово (3842)65-04-62	Новокузнецк (3843)20-46-81	Саратов (845)249-38-78	Ульяновск (8422)24-23-59
Владивосток (423)249-28-31	Киров (8332)68-02-04	Новосибирск (383)227-86-73	Севастополь (8692)22-31-93	Уфа (347)229-48-12
Волгоград (844)278-03-48	Краснодар (861)203-40-90	Омск (3812)21-46-40	Симферополь (3652)67-13-56	Хабаровск (4212)92-98-04
Вологда (8172)26-41-59	Красноярск (391)204-63-61	Орел (4862)44-53-42	Смоленск (4812)29-41-54	Челябинск (351)202-03-61
Воронеж (473)204-51-73	Курск (4712)77-13-04	Оренбург (3532)37-68-04	Сочи (862)225-72-31	Череповец (8202)49-02-64
Екатеринбург (343)384-55-89	Липецк (4742)52-20-81	Пенза (8412)22-31-16	Ставрополь (8652)20-65-13	Ярославль (4852)69-52-93
Иваново (4932)77-34-06	Киргизия (996)312-96-26-47	Казахстан (772)734-952-31	Таджикистан (992)427-82-92-69	

Единый адрес для всех регионов: fst@nt-rt.ru || www.fujitsu.nt-rt.ru

24V DRIVE, FTP-609 SERIES ULTRA HIGH SPEED (200mm/s) 3" TYPE MECHANISM (Cutter option)

FTP-639MCL353/354-R

■ OVERVIEW

The FTP-609MCL Series thermal printer (driven by 24VDC) provides ultra-high speed printing (200mm/s) for 2-inch and 3-inch wide paper.

This series is suitable for a variety of applications, such as POS/ECR, kiosk terminals, ticket machines, label printers, banking machines, measuring devices, medical equipment, etc.

■ HIGHLIGHTS

- **Ultra high speed printing**
It can print at 200 mm/s (1600 dotlines/s) maximum by using Fujitsu Components' unique head drive control.
- **Rear paper insertion with lock type**
Fujitsu Components' unique platen release mechanism allows straight paper path and easy head maintenance.
- **Auto Cutter**
Printer with auto cutter (full cut/ partial cut) is available. It can be mounted on top of the mechanism.
- **Multi-featuring diecast frame**
By application of multi-featuring diecast frame, continuous print by function of heat-sink, high ESD with stand by function of earth frame and shock/vibration resistance by function of solid frame are valid.
- **Compact size**
Depth: 40.5mm, width: 104.2mm, height: 20.5mm
- **High resolution**
8 dots/mm head provides clear print out.
- **RoHS compliant**

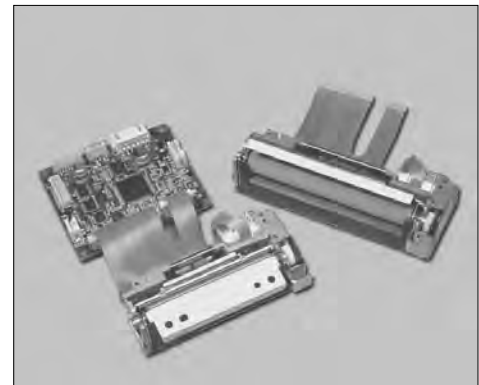

FTP-629DSL034R

FTP-639MCL353/354-R

■ PART NUMBERS

Name		Part Number		
Printer mechanism	bottom insertion	FTP-639MCL054R	FTP-639MCL074R	FTP-639MCL054R
Mechanism with cutter	front insertion	FTP-639MCL353R	TBA	FTP-639MCL353R
	bottom insertion	FTP-639MCL354R	FTP-639MCL374R	FTP-639MCL354R
LSI		FTP-629CU101R	FTP-629SR201	FTP-629CU301R
Interface board	Parallel	FTP-629DCL014R	FTP-629DSL181R*	
	Serial (RS232C)	FTP-629DSL034R	FTP-629DSL181R*	FTP-629DSL301R
	USB	---	FTP-629DSL112R	FTP-629DSL301R
Thermal head cable extension		---	FTP-629Y001	---
Interface cable	Parallel	FTP-628Y202		---
	Serial	FTP-628Y302	FTP-629Y302	
	USB	---	FTP-629Y301	
Power supply cable	Logic	FTP-629Y401	---	
	Head, motor	FTP-629Y601		FTP-629Y602

*: Interface is selectable by DIP switch

■ GENERAL SPECIFICATIONS

Item		Specifications	
Part number		FTP-639MCL054/074-R	FTP-629MCL354/374-R
Printing method		Thermal sensitive line dot method	
Dot structure		576 dots/line	
Dot pitch (horizontal)		0.125mm (8dots/mm) - Dot density	
Dot pitch (vertical)		0.125mm (8dots/mm) - Line feed pitch	
Effective printing area		72 mm	
Number of columns		ANK 48 columns/line (12 x 24 dot font), OCR 24 columns (24x40)	
Paper width		82.5 mm +0/-1	
Paper thickness		60 to 150µm	60 to 100µm
Cutting type		---	full or partial
Printing speed		FTP-629DCL/DSL series	FTP-629DSL100 series/ FTP-629DSL300 series
		80mm/sec. (640 dot lines/sec.) line mode 200mm/sec. (1600 dot lines/sec.) image mode	125mm/sec. (1000 dot lines/sec.) line mode 200mm/sec. (1600 dot lines/sec.) page mode
Interface types		FTP-629DCL/DSL series FTP-629DCL/DSL100 series	FTP-629DSL300 series
Character types	Alphanumeric, Kana: International and special OCR I OCR III OCR IV Extended numeric JIS Kanji level 1, level 2, non-Kanji	159 types 195 types about 6,800 types	159 types 195 types 103 types 23 types 103 types 11 types about 6,800 types
Character, dimensions (WxH), number of columns		(8x16 dots), 72 columns: ANK (12x24 dots), 48 columns: ANK (16x16 dots), 36 columns: ANK (24x24 dots), 24 columns: ANK	(24 x 40 dots), 24 columns, OCR I (24 x 48 dots), 24 columns, OCR II (36 x 60 dots), 16 columns, OCR IV (24 x 48 dots) 24 columns, extended numeric
Interface standard		Centronics, RS-232C, USB	Serial /USB

FTP-639MCL353/354-R

Item		Specifications	
Part number		FTP-639MCL054/074-R	FTP-639MCL354/374-R
Power supply	For head	24 VDC \pm 5% 1.9A (4A,)(24V , 25% printing ratio)	
	For printer motor	24VDC \pm 5% 1A maximum	
	For cutter motor	---	24VDC \pm 5% 1.2A maximum
	For logic	5VDC \pm 5% 0.2 A maximum	
Dimensions W x D x H	Printer Mechanism	104.4 x 40.5 x 20.5mm	---
	Printer Mechanism with cutter	---	110.4 x 62.5 x 37.7mm
	Interface board (DCL/DSL)	70 x 60 x 21.6 mm	
	Interface board (DSL100)	95 x 73.5 x 11.6mm	
	Interface board (DCL300)	77 x 50 x 21.5mm	
Weight	Printer Mechanism	Approximately 125g	---
	Printer Mechanism with cutter	---	Approximately 320g
	Interface board (standard)	Approximately 25g	
	Interface board (med speed)	Approximately 45g	
Life	Interface board (hi speed)	Approximately 22g	
	Head	Pulse durability: 100 million pulse/dot (using Fujitsu Components' standard driving method) Wear resistance: 100 km (at 12.5% print ratio)	
	Cutter	---	500,000 cuts
Environmental conditions	Operating temperature	-10°C to +60°C (Guarantee)	0°C to +50°C (Guarantee)
	Operating humidity	20 to 85% RH (no condensation)	
	Storage temperature	-40°C to +70°C (excluding paper)	-20°C to +60°C
	Storage humidity	5 to 95% RH (no condensation)	
Detection	Head temperature	By thermistor	
	Paper out/Mark detect	By photointerrupter	
	Head release	By slide switch	
	Cutter position	By microswitch (inside cutter)	
	High sensitivity paper	TF50KS-E4 (Nippon paper)	
Recommended thermal sensitive paper	Standard paper	TF60KS-E (Nippon paper), FTP-030P0104 (80mm), PD150R (Oji paper), FTP-030P0701 (80mm)	
	Medium term paper	TP60KS-F1 (Nippon paper), FTP-030P0102(80mm), PD170R (Oji paper) P220VBB-1 (Mitsubishi paper) PD160R-N (Oji paper)	
	Long term paper	AFP-235 (Mitsubishi paper) TP50KJ-R (Nippon paper) HA220AA (Nippon paper)	
	Label paper	HW54T (Nippon paper)	

FTP-639MCL353/354-R

FUNCTION

ITEM		ITEM	
1.	Test printing	8.	Cutter trouble detection
2.	Paper-out detection	9.	Motor power save
3.	Paper near end detection	10.	Mark detection
4.	Head-up detection	11.	MCU trouble detection
5.	Abnormal temp. of thermal head detection	12.	Power on/off sequence protection
6.	Blown fuse detection	13.	Motor protection
7.	Abnormal voltage detection of head	14.	Hardware timer

DIMENSIONS

1. Printer mechanism

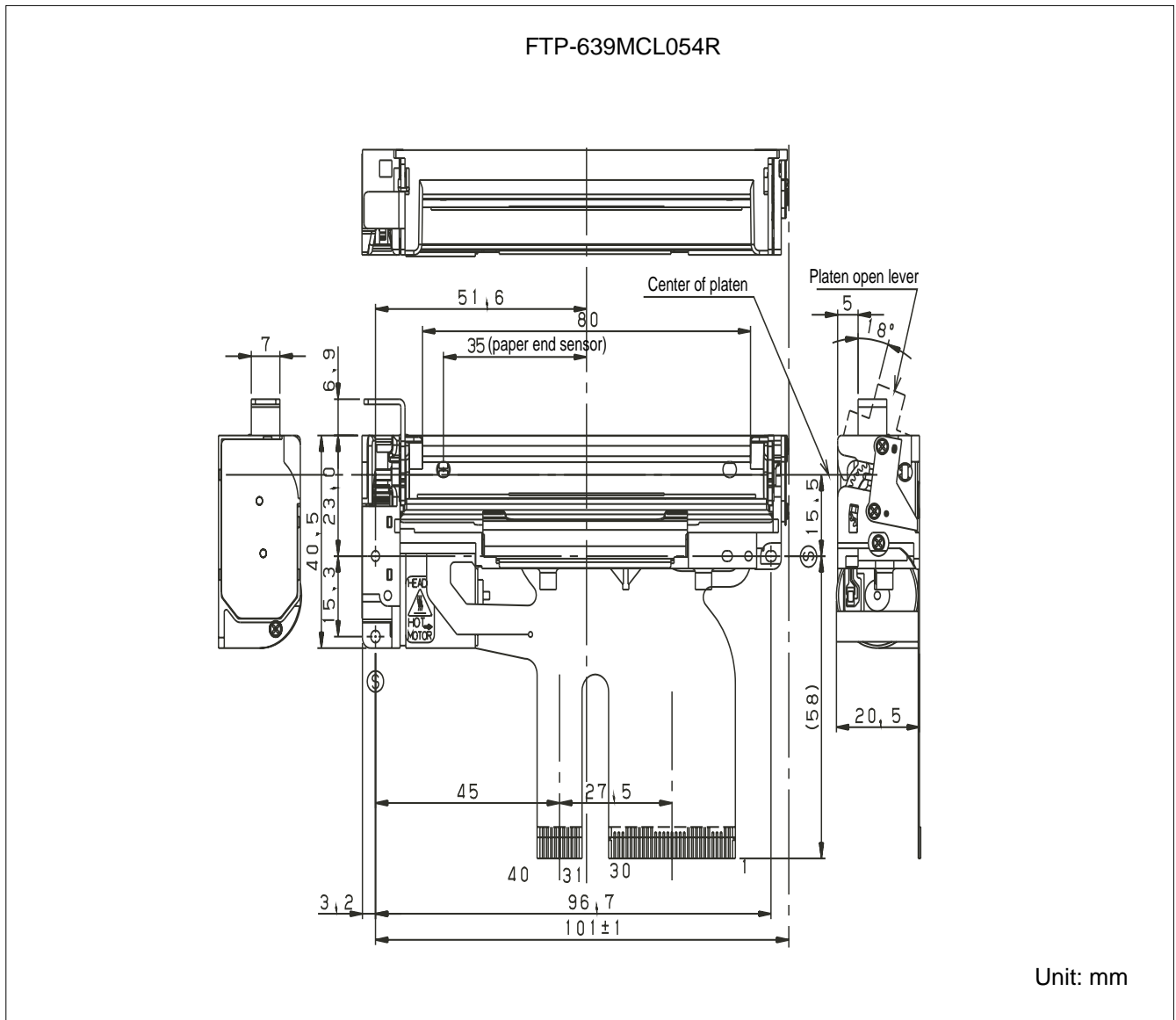

FTP-639MCL353/354-R

Printer with cutter

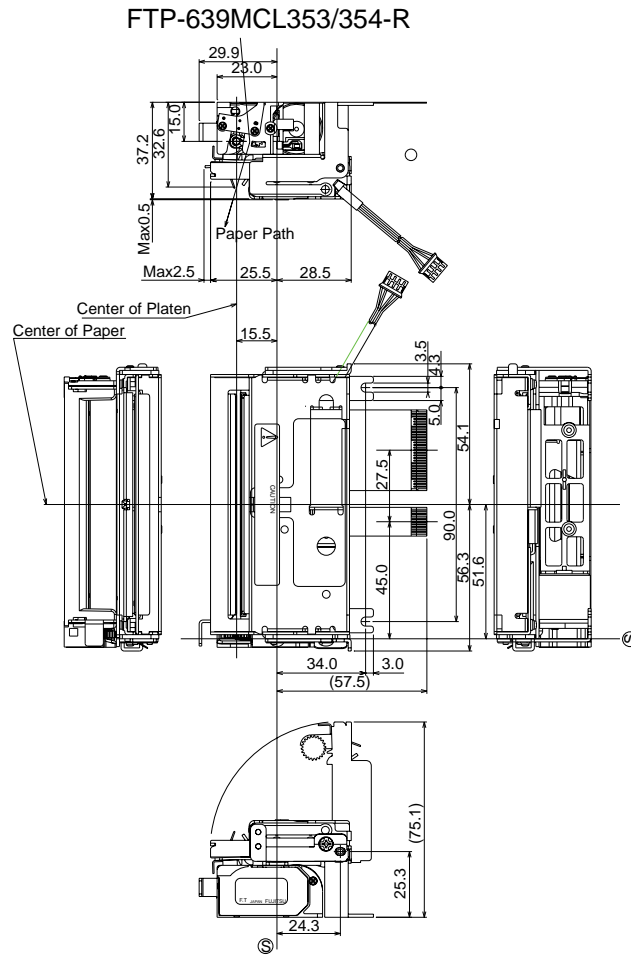

- Notes: 1. Nominal value (Tolerance +0.5, -0.5)
2. S is the base line of installing (Tolerance +0.5, -0.5)

Unit: mm

■ CONNECTOR PIN ASSIGNMENT OF PRINTER MECHANISM (FPC)

1. Thermal head control circuit side

Part number : 52610-3071 (Molex) or equivalent

No	Signal	I/O	Contents	No	Signal	I/O	Contents
1	SW	O	Platen open switch	2	SW	-	Platen open switch
3	VH	-	Power for thermal head	4	VH	-	Power for thermal head
5	VH	-	Power for thermal head	6	VH	-	Power for thermal head
7	DI	I	Data in	8	$\overline{\text{STB3}}$	I	Print enable 3
9	$\overline{\text{STB4}}$	I	Print enable 4	10	VDD	-	Power for logic
11	TM	-	Head Thermistor	12	GND	-	Head GND
13	GND	-	Head GND	14	GND	-	Head GND
15	GND	-	Head GND	16	GND	-	Head GND
17	GND	-	Head GND	18	GND	-	Head GND
19	GND	-	Head GND	20	GND	-	Head GND
21	TH	O	Thermistor	22	$\overline{\text{STB1}}$	I	Print enable 1
23	$\overline{\text{STB2}}$	I	Print enable 2	24	$\overline{\text{LAT}}$	I	Print data latch
25	CLK	I	Clock	26	DO	O	Data out
27	VH	-	Power for thermal head	28	VH	-	Power for thermal head
29	VH	-	Power for thermal head	30	VH	-	Power for thermal head

2. Motor, Sensor

Connector on circuit side : 52610-1071 (Molex) or equivalent

No.	Signal	I/O	Contents	No.	Signal	I/O	Contents
1	NC	-	Not connected	2	TM	O	Motor temperature sensor
3	TM	-	Motor temperature sensor	4	$\overline{\text{MT A}}$	I	Motor coil excitation /A
5	MT A	I	Motor coil excitation A	6	$\overline{\text{MT B}}$	I	Motor coil excitation /B
7	MT B	I	Motor coil excitation B	8	PHK	-	Paper out sensor cathode
9	VSEN	I	Power for paper sensor	10	PHE	O	Paper out sensor emittor

3. Cutter

Connector type: B4B-PH-SM4-TB (J.S.T.) or equivalent

No.	Signal	I/O	Contents	No.	Signal	I/O	Contents
1	SW1	-	Cutter home position switch	2	SW2	O	Cutter home position switch
3	M+	O	Cutter motor drive	4	M-	I	Cutter motor drive

■ INTERFACE COMMAND OPTIONS

Please refer to the FTP-629DCL/DSL or FTP-629DCL/DSL100/300 datasheet series datasheet.

Архангельск (8182)63-90-72	Ижевск (3412)26-03-58	Магнитогорск (3519)55-03-13	Пермь (342)205-81-47	Сургут (3462)77-98-35
Астана (7172)727-132	Иркутск (395)279-98-46	Москва (495)268-04-70	Ростов-на-Дону (863)308-18-15	Тверь (4822)63-31-35
Астрахань (8512)99-46-04	Казань (843)206-01-48	Мурманск (8152)59-64-93	Рязань (4912)46-61-64	Томск (3822)98-41-53
Барнаул (3852)73-04-60	Калининград (4012)72-03-81	Набережные Челны (8552)20-53-41	Самара (846)206-03-16	Тула (4872)74-02-29
Белгород (4722)40-23-64	Калуга (4842)92-23-67	Нижний Новгород (831)429-08-12	Санкт-Петербург (812)309-46-40	Тюмень (3452)66-21-18
Брянск (4832)59-03-52	Кемерово (3842)65-04-62	Новокузнецк (3843)20-46-81	Саратов (845)249-38-78	Ульяновск (8422)24-23-59
Владивосток (423)249-28-31	Киров (8332)68-02-04	Новосибирск (383)227-86-73	Севастополь (8692)22-31-93	Уфа (347)229-48-12
Волгоград (844)278-03-48	Краснодар (861)203-40-90	Омск (3812)21-46-40	Симферополь (3652)67-13-56	Хабаровск (4212)92-98-04
Вологда (8172)26-41-59	Красноярск (391)204-63-61	Орел (4862)44-53-42	Смоленск (4812)29-41-54	Челябинск (351)202-03-61
Воронеж (473)204-51-73	Курск (4712)77-13-04	Оренбург (3532)37-68-04	Сочи (862)225-72-31	Череповец (8202)49-02-64
Екатеринбург (343)384-55-89	Липецк (4742)52-20-81	Пенза (8412)22-31-16	Ставрополь (8652)20-65-13	Ярославль (4852)69-52-93
Иваново (4932)77-34-06	Киргизия (996)312-96-26-47	Казахстан (772)734-952-31	Таджикистан (992)427-82-92-69	

Единый адрес для всех регионов: fst@nt-rt.ru || www.fujitsu.nt-rt.ru